



Vestil Manufacturing Corp.
 2999 North Wayne Street, P.O. Box 507, Angola, IN 46703
 Telephone: (260) 665-7586 -or- Toll Free (800) 348-0868
 Fax: (260) 665-1339
<http://www.vestilmfg.com/> e-mail: sales@vestil.com

HDD-Series Hydraulic Drum Dumpers Instruction Manual



Receiving instructions:

After delivery, IMMEDIATELY remove the packaging from the product in a manner that preserves the packaging and maintains the orientation of the product in the packaging; then inspect the product closely to determine whether it sustained damage during transport. If damage is discovered during the inspection, immediately record a complete description of the damage on the bill of lading. If the product is undamaged, discard the packaging.

NOTES:

1) Compliance with laws, regulations, codes, and non-voluntary standards enforced in the location where the product is *used* is exclusively the responsibility of the owner/end-user.

2) VESTIL is not liable for any injury or property damage that occurs as a consequence of failing to apply either:
 a) Instructions in this manual; or b) information provided on labels affixed to the product.

Vestil is also not responsible for *any* consequential damages sustained as a result of failing to exercise sound judgment while assembling, installing, using or maintaining this product.

Table of Contents

Product Specifications.....	2-3
Signal Words.....	4
Safe Use Recommendations.....	4
Installation Instructions.....	11
Loading the Dumper.....	11
Inspections.....	11-12
Power unit operation.....	12-13
Troubleshooting guide.....	23
Labeling Diagram.....	24
Limited warranty.....	25

Table of Figures

FIG. 1: HDD-36-S exploded parts diagram.....	5
FIG. 2: HDD-48-S exploded parts diagram.....	5
FIG. 3: HDD-60-S exploded parts diagram.....	6
FIG. 4: HDD-72-S exploded parts diagram.....	6
FIG. 5: HDD-36-P exploded parts diagram.....	7
FIG. 6: HDD-48-P exploded parts diagram.....	8
FIG. 7: HDD-60-P exploded parts diagram.....	9
FIG. 8: HDD-72-S exploded parts diagram.....	10
FIG. 9: Hydraulic Circuit Diagram.....	13
FIGS. 10A-10F: Electrical Circuit Diagrams.....	14-19
FIG. 11: Motor Lead Diagrams & Transformer diagram....	20
FIGS. 12A-12B: Modular Power Unit parts diagram.....	21-22

Product Specifications:

Dimensions and other product attributes appear in the diagrams and table below:

Stationary (bolt-down) HDD models

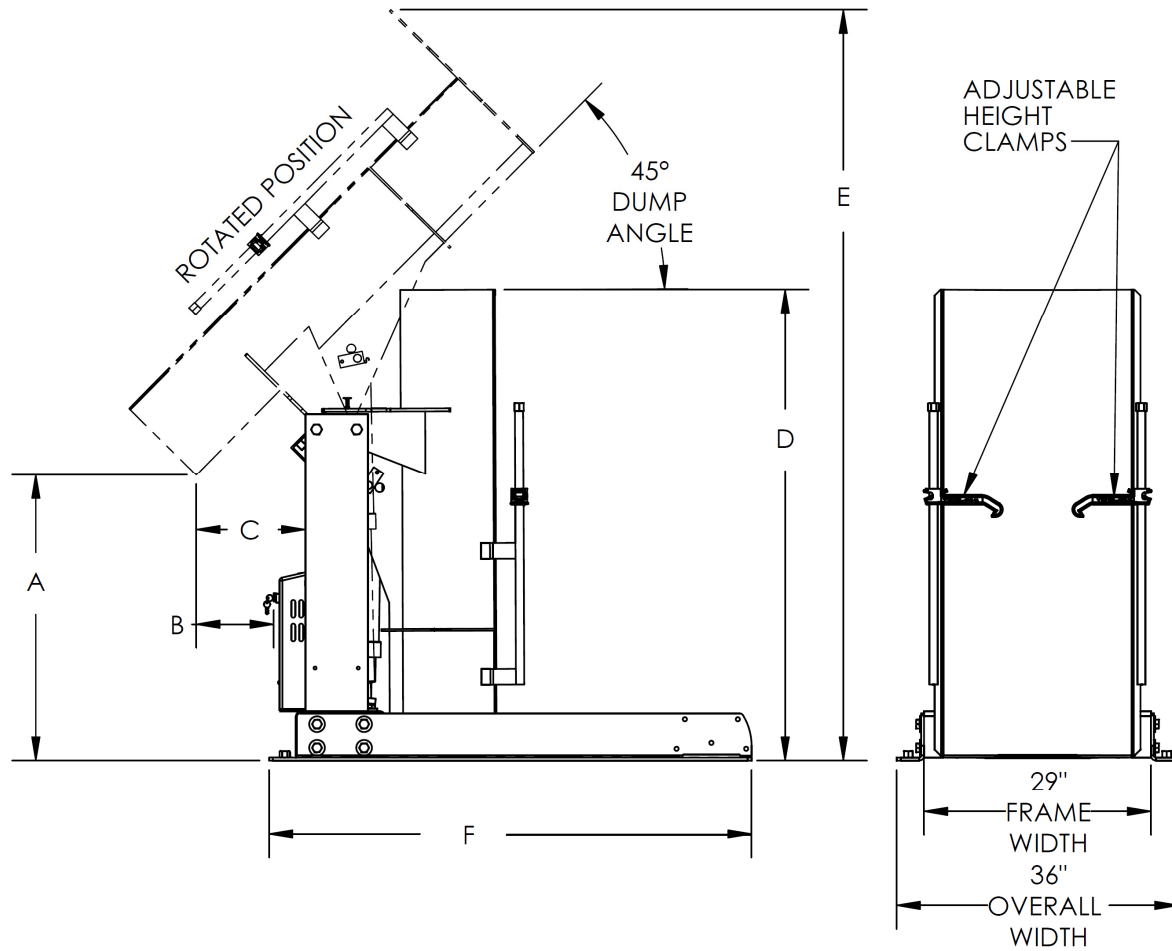

Model	A	B	C	D	E	F	Capacity	Net weight
HDD-36-7-S	36"	9 ³ / ₄ "	14"	60"	95 ³ / ₄ "	61 ¹ / ₂ "	750 lb.	582.8 lb.
HDD-36-10-S	36"	9 ³ / ₄ "	14"	60"	95 ³ / ₄ "	61 ¹ / ₂ "	1,000 lb.	582.8 lb.
HDD-36-15-S	36"	9 ³ / ₄ "	14"	60"	95 ³ / ₄ "	61 ¹ / ₂ "	1,500 lb.	582.8 lb.
HDD-48-7-S	48"	9 ³ / ₄ "	14"	72"	116"	71 ¹ / ₂ "	750 lb.	668.0 lb.
HDD-48-10-S	48"	9 ³ / ₄ "	14"	72"	116"	71 ¹ / ₂ "	1,000 lb.	668.0 lb.
HDD-48-15-S	48"	9 ³ / ₄ "	14"	72"	116"	71 ¹ / ₂ "	1,500 lb.	668.0 lb.
HDD-60-7-S	60"	9 ³ / ₄ "	14"	84"	136 ³ / ₄ "	80"	750 lb.	791.1 lb.
HDD-60-10-S	60"	9 ³ / ₄ "	14"	84"	136 ³ / ₄ "	80"	1,000 lb.	791.1 lb.
HDD-60-15-S	60"	9 ³ / ₄ "	14"	84"	136 ³ / ₄ "	80"	1,500 lb.	791.1 lb.
HDD-72-7-S	72"	9 ¹ / ₂ "	13 ¹ / ₂ "	96"	157 ¹ / ₄ "	92"	750 lb.	870.8 lb.
HDD-72-10-S	72"	9 ¹ / ₂ "	13 ¹ / ₂ "	96"	157 ¹ / ₄ "	92"	1,000 lb.	870.8 lb.
HDD-72-15-S	72"	9 ¹ / ₂ "	13 ¹ / ₂ "	96"	157 ¹ / ₄ "	92"	1,500 lb.	870.8 lb.

Portable HDD models

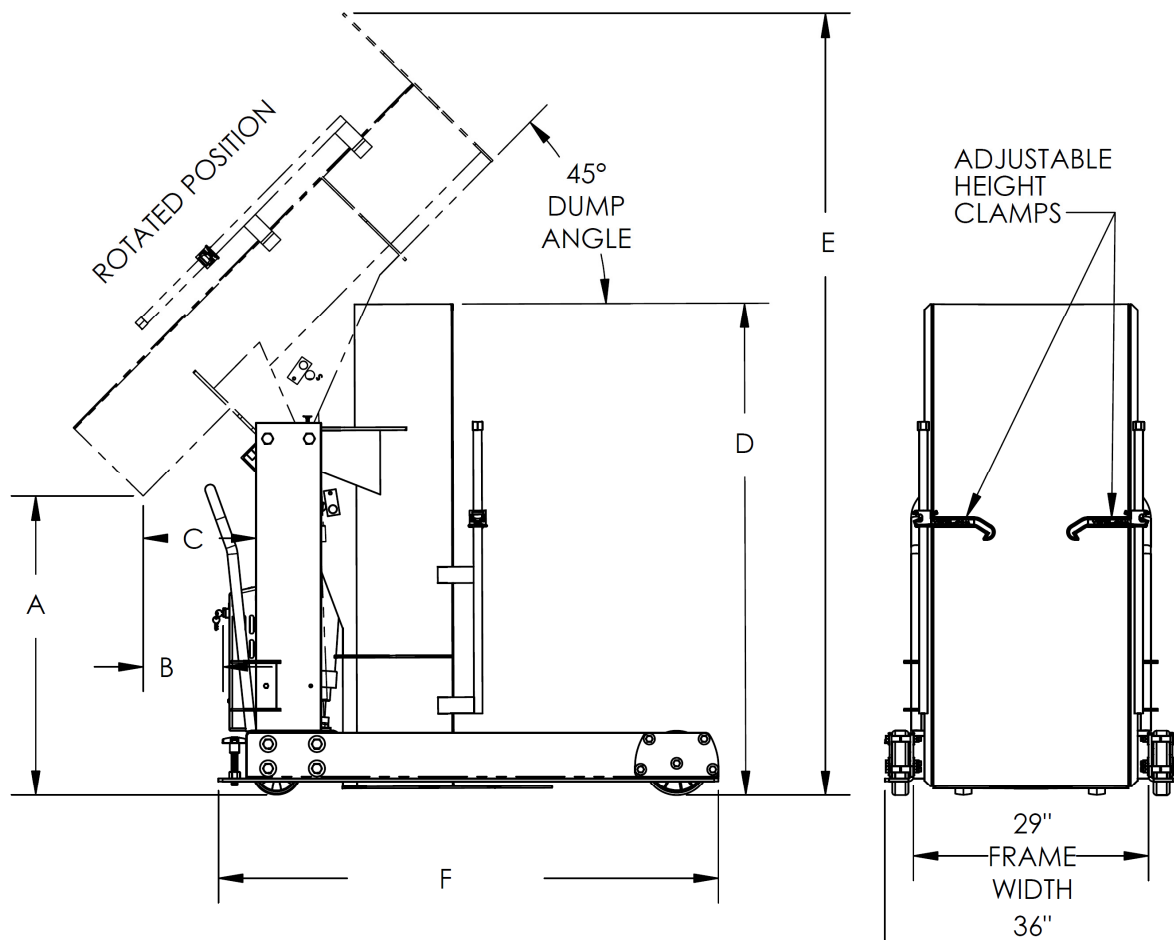

Model	A	B	C	D	E	F	Time to full rotation	Capacity	Net weight
HDD-36-7-P	36"	9 ³ / ₄ "	14"	63 ³ / ₄ "	96"	61 ¹ / ₂ "	25 seconds	750 lb.	582.8 lb.
HDD-36-10-P	36"	9 ³ / ₄ "	14"	63 ³ / ₄ "	96"	61 ¹ / ₂ "	25 seconds	1,000 lb.	582.8 lb.
HDD-36-15-P	36"	9 ³ / ₄ "	14"	63 ³ / ₄ "	96"	61 ¹ / ₂ "	30 seconds	1,500 lb.	582.8 lb.
HDD-48-7-P	48"	9 ³ / ₄ "	14"	72 ¹ / ₂ "	116 ³ / ₄ "	71 ¹ / ₂ "	25 seconds	750 lb.	668.0 lb.
HDD-48-10-P	48"	9 ³ / ₄ "	14"	72 ¹ / ₂ "	116 ³ / ₄ "	71 ¹ / ₂ "	25 seconds	1,000 lb.	668.0 lb.
HDD-48-15-P	48"	9 ³ / ₄ "	14"	72 ¹ / ₂ "	116 ³ / ₄ "	71 ¹ / ₂ "	30 seconds	1,500 lb.	668.0 lb.
HDD-60-7-P	60"	9 ³ / ₄ "	14"	84 ¹ / ₂ "	137 ¹ / ₄ "	80"	25 seconds	750 lb.	791.1 lb.
HDD-60-10-P	60"	9 ³ / ₄ "	14"	84 ¹ / ₂ "	137 ¹ / ₄ "	80"	25 seconds	1,000 lb.	791.1 lb.
HDD-60-15-P	60"	9 ³ / ₄ "	14"	84 ¹ / ₂ "	137 ¹ / ₄ "	80"	30 seconds	1,500 lb.	791.1 lb.
HDD-72-7-P	72"	9 ¹ / ₄ "	13 ¹ / ₂ "	96"	157 ¹ / ₂ "	92"	25 seconds	750 lb.	870.8 lb.
HDD-72-10-P	72"	9 ¹ / ₄ "	13 ¹ / ₂ "	96"	157 ¹ / ₂ "	92"	25 seconds	1,000 lb.	870.8 lb.
HDD-72-15-P	72"	9 ¹ / ₄ "	13 ¹ / ₂ "	96"	157 ¹ / ₂ "	92"	30 seconds	1,500 lb.	870.8 lb.

SIGNAL WORDS:

This manual uses SIGNAL WORDS to indicate the likelihood of personal injuries, as well as the probable seriousness of those injuries, if the product is misused in the ways described. Other signal words call attention to uses of the product likely cause property damage. The signal words used appear below along with the meaning of each word:



Identifies a hazardous situation which, if not avoided, **WILL** result in DEATH or SERIOUS INJURY. Use of this signal word is limited to the most extreme situations.



Identifies a hazardous situation which, if not avoided, **COULD** result in DEATH or SERIOUS INJURY.



Indicates a hazardous situation which, if not avoided, **COULD** result in MINOR or MODERATE injury.



Identifies practices likely to result in product/property damage, such as operation that might damage the product.

Safe Use Recommendations:

We strive to identify all hazards associated with the use of our products. However, material handling is dangerous and no manual can address every risk. Ultimately, the most effective way to avoid injury is to exercise sound judgment whenever using this product.



Improper or careless operation of this drum dumper might result in serious personal injuries.

- ***Failure to read and understand the entire manual before assembling, using or servicing the product constitutes misuse.*** Read the manual whenever necessary to refresh your understanding of proper use and maintenance procedures.
- **ONLY** use the dumper as a means for mechanically emptying drum. **ALWAYS** properly load the dumper according to the directions on p. 11.
- **DO NOT** use a damaged dumper. Examples of structural damage include: broken container restraining tube, broken fork pockets, and holes caused by rust or corrosion. Inspect the dumper before each use according to the inspection instructions on p. 11-12. **DO NOT** use the HBD unless it passes *every* element of the inspection, or until authorized maintenance personnel approve the dumper for service.
- Inspect the unit before each use according to the inspection instructions on p. 11-12.
- **DO NOT** stand beneath or travel under the dumper chute while it is elevated.
- **DO NOT** use this dumper **UNLESS** every label shown in the “Labeling diagram” on p. 24 is in place, undamaged, and easily readable.
- **DO NOT** exceed the capacity of the dumper. The capacity of each model appears in the tables on pp. 2-3 as well as on label 287 (see “Labeling diagram” on p. 24). The weight of the container to be dumped plus the weight of its contents must not exceed the capacity.
- **DO NOT** modify the dumper in any way **UNLESS** you first obtain written approval from Vestil. Modifying the dumper without first receiving approval automatically voids the limited warranty and might make the dumper unsafe to use.



DO NOT fill the hydraulic system with brake fluid or jack oils. Only fill the hydraulic system with either anti-wear hydraulic oil, viscosity grade 150 SUS at 100°F (ISO 32cSt at 40°C) or Dexron transmission fluid.

FIG. 1: HDD-36-S series stationary dumpers exploded parts diagram and bill of materials

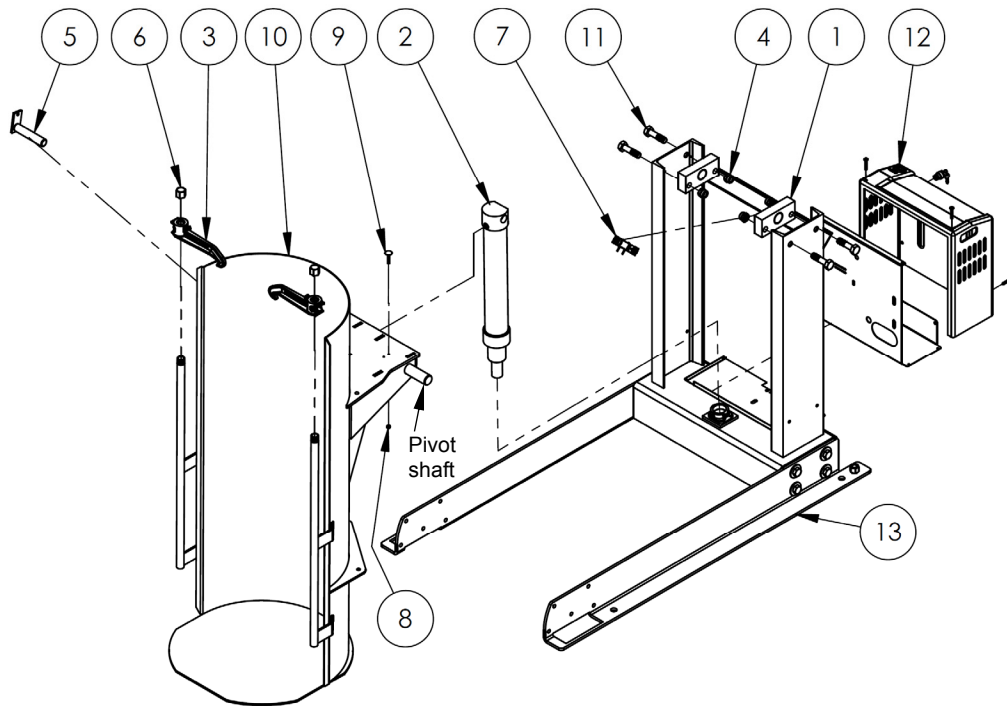

Item no.	Part no.	Description	Qty	Item no.	Part no.	Description	Qty
1	09-512-001	Hinge block assembly	2	8	36102	Hex nut, grade A, zinc-plated, 1/4" - 20	1
2	99-021-909	Hydraulic cylinder, 2 1/2" x 18"	1	9	22805	Elevator bolt, limit switch	1
3	09-537-013	Assembly, drum clamp, casting	2	10	09-545-028	Weldment, subassembly, chute	1
4	37039	Nylock nut, zinc-plated, 3/4" - 10	4	11	12365	3/4" - 10UNC x 3" zinc-plated #5 bolt	4
5	24-511-030	Pin assembly, cylinder	1	12	99-158-008	Modular power unit, no push buttons	1
6	09-145-020	Threaded pipe cap	2	13	09-514-131	Weldment, frame, stationary	1
7	01-022-021	Switch, limit, roller arm	1				

FIG. 2: HDD-48-S series stationary dumpers exploded parts diagram and bill of materials

Item no.	Part no.	Description	Quantity
1	09-514-129	Weldment, frame, stationary	1
2	09-512-001	Hinge block assembly	2
3	99-021-909	Hydraulic cylinder, 2 1/2" x 18"	1
4	09-537-013	Assembly, drum clamp, casting	2
5	37039	Nylock nut, zinc-plated, 3/4" - 10	4
6	24-511-030	Pin assembly, cylinder, box dumper	1
7	09-145-020	Threaded pipe cap	2
8	01-022-021	Switch, limit, roller arm	1
9	36102	Hex nut, grade A, zinc-plated, 1/4" - 20	1
10	22805	Elevator bolt, limit switch	1
11	09-545-030	Weldment, subassembly, chute	1
12	13365	3/4" - 10 UNC x 3" zinc-plated #5 bolt	4
13	99-158-008	Modular power unit w/out push buttons	1

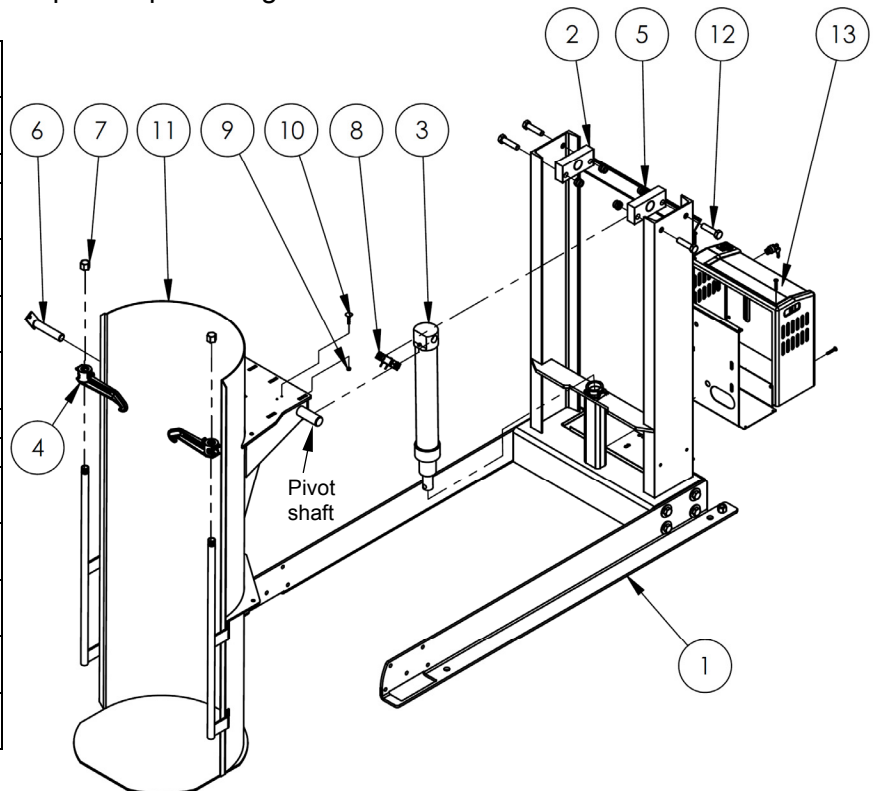
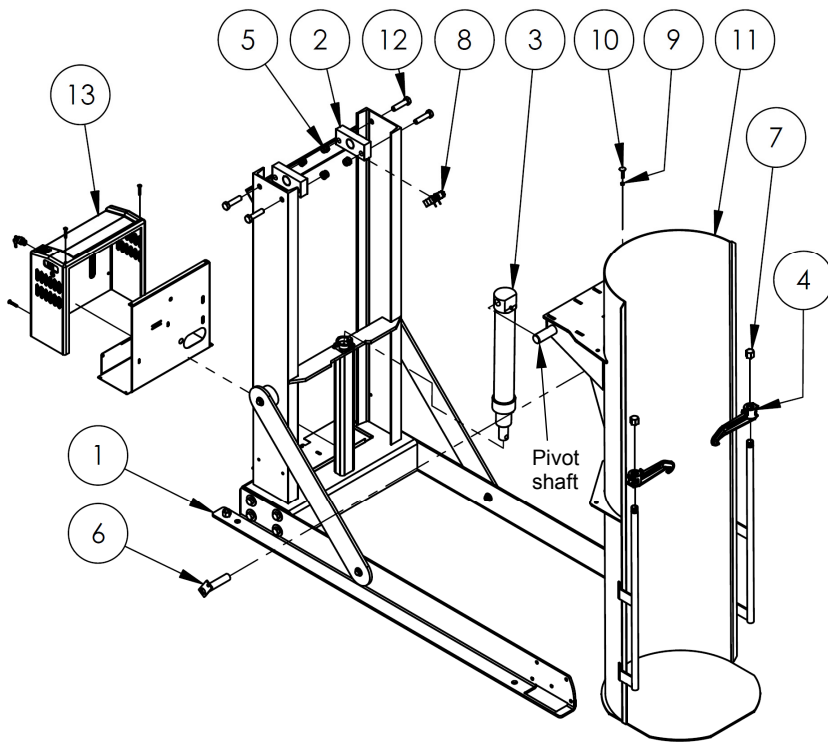
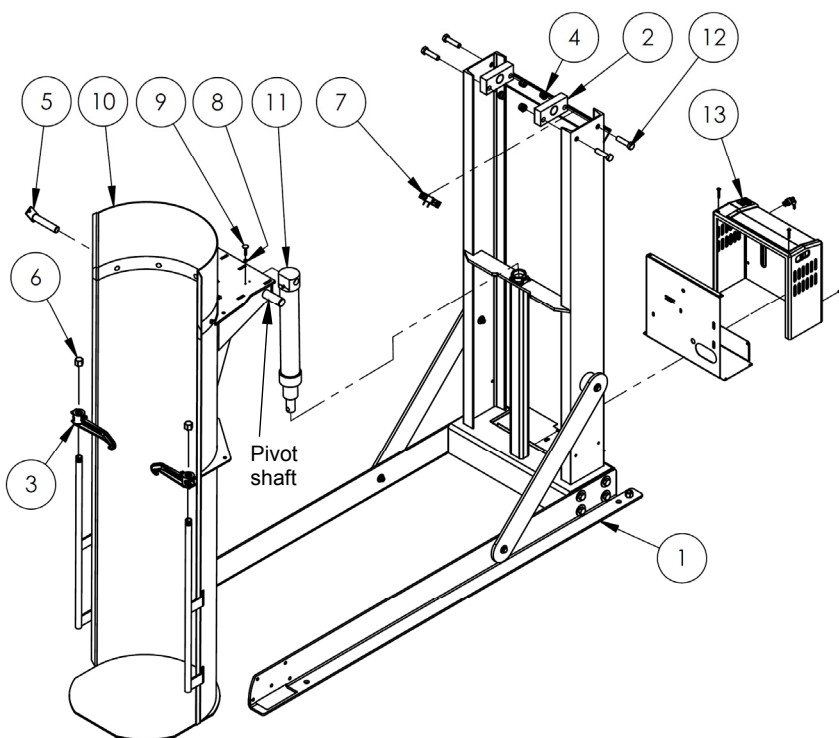

FIG. 3: HDD-60-S series stationary dumpers exploded parts diagram and bill of materials



Item no.	Part no.	Description	Quantity
1	09-514-127	Weldment, frame, stationary	1
2	09-512-001	Hinge block assembly	2
3	99-021-909	Hydraulic cylinder, 2 1/2" x 18"	1
4	09-537-013	Assembly, drum clamp, casting	2
5	37039	Nylock nut, zinc-plated, 3/4" - 10	4
6	09-612-011	Pin assembly, cylinder, box dumper	1
7	09-145-020	Threaded pipe cap	2
8	01-022-021	Switch, limit, roller arm	1
9	36102	Hex nut, grade A, zinc-plated, 1/4" - 20	1
10	22805	Elevator bolt, limit switch	1
11	09-545-031	Weldment, subassembly, chute	1
12	13365	3/4" - 10 UNC x 3" zinc-plated #5 bolt	4
13	99-158-008	Modular power unit w/out push buttons	1

FIG. 4: HDD-72-S series stationary dumpers exploded parts diagram and bill of materials



Item no.	Part no.	Description	Quantity
1	09-514-125	Weldment, frame, stationary	1
2	09-512-001	Hinge block assembly	2
3	09-537-013	Assembly, drum clamp, casting	2
4	37039	Nylock nut, zinc-plated, 3/4" - 10	4
5	24-511-030	Pin assembly, cylinder, box dumper	1
6	09-145-020	Threaded pipe cap	2
7	01-022-021	Switch, limit, roller arm	1
8	36102	Hex nut, grade A, zinc-plated, 1/4" - 20	1
9	22805	Elevator bolt, limit switch	1
10	09-545-032	Weldment, subassembly, chute	1
11	99-021-909	Hydraulic cylinder: 2 1/2" x 18"	1
	09-021-018	3" x 18" (HDD-72-15-S)	1
12	13365	3/4" - 10 UNC x 3" zinc-plated #5 bolt	4
13	99-158-008	Modular power unit w/out push buttons	1

FIG. 5: HDD-36-P series portable dumpers exploded parts diagram and bill of materials

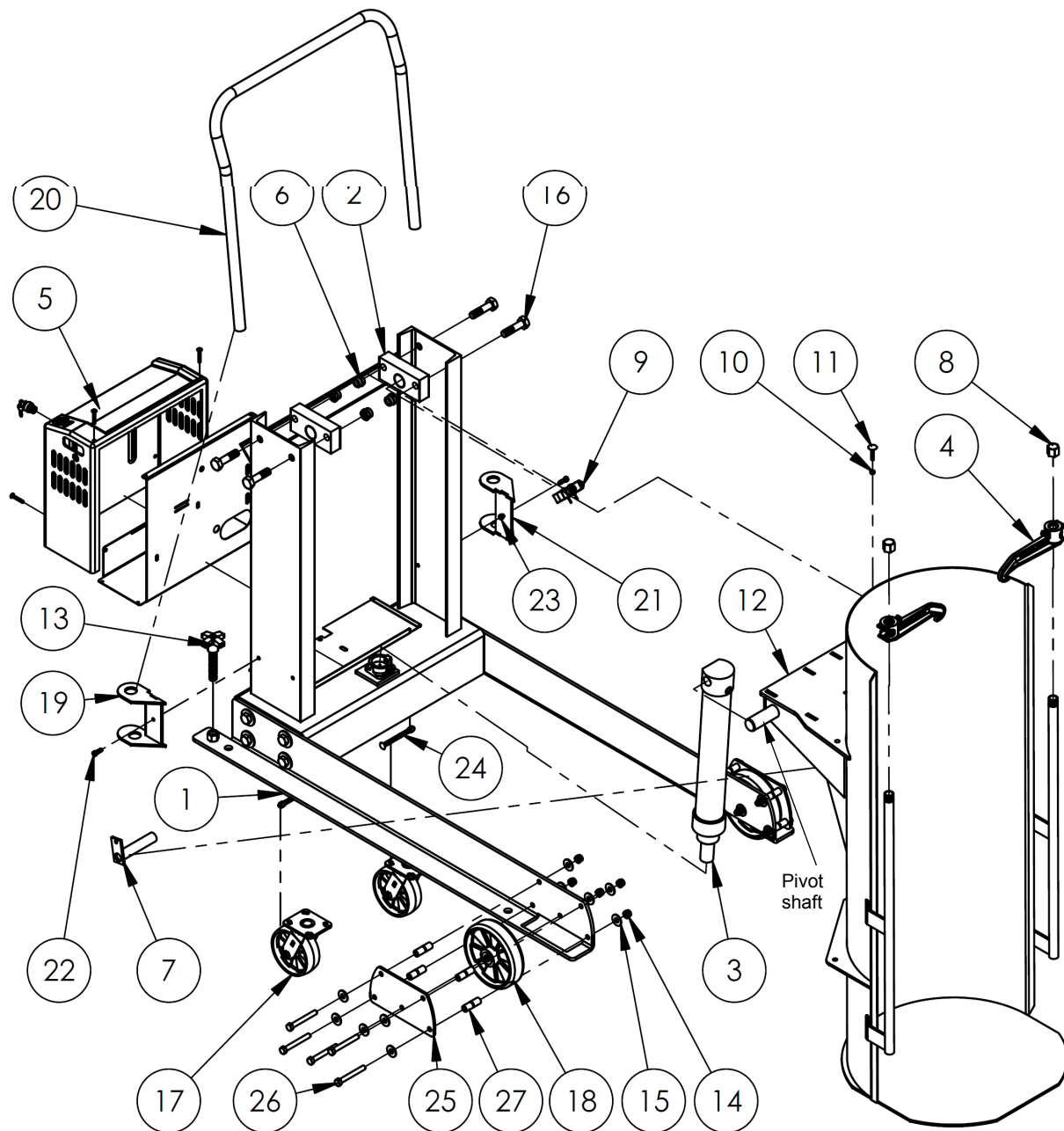

Item no.	Part no.	Description	Qty	Item no.	Part no.	Description	Qty
1	09-514-131	Weldment, frame, stationary	1	15	33012	$\frac{1}{2}$ " flat washer, low carbon, zinc finish	20
2	09-512-001	Hinge block assembly	2	16	12365	$\frac{3}{4}$ " - 10 x 3" HHCS #5 plain bolt	4
3	99-021-909	Hydraulic cylinder, 2 $\frac{1}{2}$ " x 18"	1	17	16-132-262	6" x 2" glass filled nylon swivel caster	2
4	09-537-013	Assembly, drum clamp, casting	2	18	16-132-216	Caster, 8", glass filled nylon	2
5	99-158-008	Modular power unit, no push buttons	1	19	09-525-009	Weldment, handle bracket, right	1
6	37039	Nylock nut, zinc-plated, $\frac{3}{4}$ " - 10	4	20	16-025-028	Handle, push handles, chromed	1
7	24-511-030	Pin assembly, cylinder	1	21	09-525-008	Weldment, handle bracket, left	1
8	09-145-020	Threaded pipe cap	2	22	11055	$\frac{3}{16}$ " - 18 x 1" HHCS #2 zinc-plated bolt	2
9	01-022-021	Switch, limit, roller arm	1	23	36104	$\frac{3}{16}$ " - 18 grade A zinc-plated hex nut	2
10	36102	Hex nut, grade A, zinc-plated, $\frac{1}{4}$ " - 20	1	24	99-612-001	$\frac{3}{8}$ " - 16 x 5" bolt and nut combo.	2
11	22805	Elevator bolt, limit switch	1	25	09-016-169	Bracket, wheel	2
12	09-545-028	Weldment, subassembly, chute	1	26	11219	$\frac{1}{2}$ " - 13 x 4" hex head bolt	10
13	08-025-008	4-handle bolt, 4"	2	27	16-111-003	Sleeve bearing for 2" wheel	8
14	37030	$\frac{1}{2}$ " - 13 nylon insert lock nut	10				

FIG. 6: HDD-48-P series portable dumpers exploded parts diagram and bill of materials

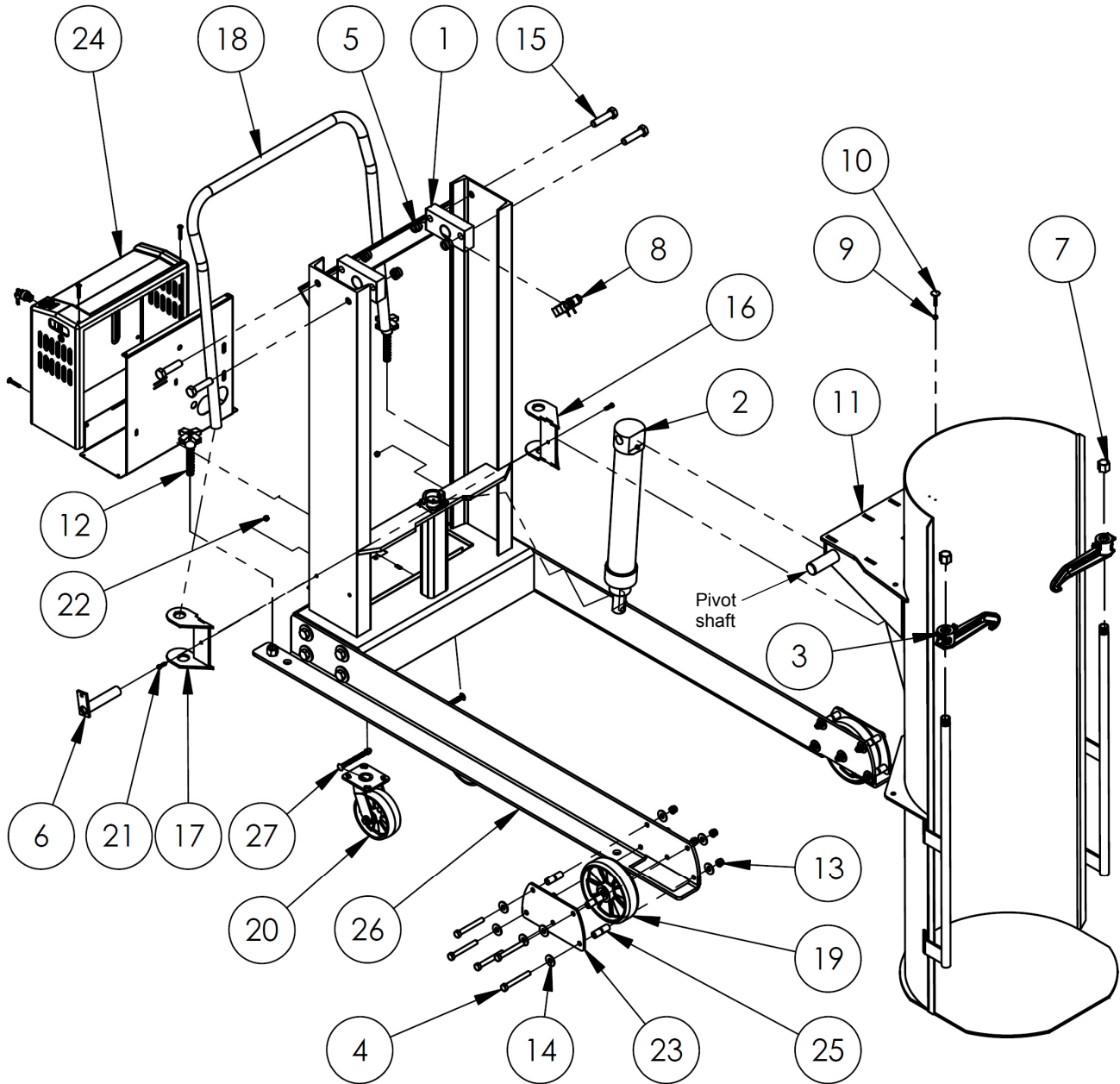

Item no.	Part no.	Description	Qty	Item no.	Part no.	Description	Qty
1	09-512-001	Hinge block assembly	2	15	13365	$\frac{3}{4}$ " - 10 x 3" HHCS #5 plain bolt	4
2	99-021-909	Hydraulic cylinder, 2 $\frac{1}{2}$ " x 18"	1	16	09-525-008	Weldment, handle bracket, left	1
3	09-537-013	Assembly, drum clamp, casting	2	17	09-525-009	Weldment, handle bracket, right	1
4	11219	$\frac{1}{2}$ " - 13 x 4" hex head bolt	10	18	16-025-028	Handle, push handles, chromed	1
5	37039	Nylock nut, zinc-plated, $\frac{3}{4}$ " - 10	4	19	16-132-216	Caster, 8", glass filled nylon	2
6	24-511-030	Pin assembly, cylinder	1	20	16-132-262	6" x 2" glass filled nylon swivel caster	2
7	09-145-020	Threaded pipe cap	25	21	11005	$\frac{1}{4}$ " - 20 x 1" HHCS #2 zinc-plated bolt	2
8	01-022-021	Switch, limit, roller arm	1	22	36104	$\frac{9}{16}$ " - 18 grade A zinc-plated hex nut	2
9	36102	Hex nut, grade A, zinc-plated, $\frac{1}{4}$ " - 20	1	23	09-016-169	Bracket, wheel	2
10	22805	Elevator bolt, limit switch	1	24	99-158-008	Modular power unit, no push buttons	1
11	09-545-030	Weldment, subassembly, chute	1	25	16-111-003	Sleeve bearing for 2" wheel	8
12	08-025-008	4-handle bolt, 4"	2	26	09-514-131	Weldment, frame, stationary	1
13	37030	$\frac{1}{2}$ " - 13 nylon insert lock nut	10	27	99-612-001	$\frac{3}{8}$ " - 16 x 5" bolt and nut combo.	2
14	33012	$\frac{1}{2}$ " flat washer, low carbon, zinc finish	20				

FIG. 7: HDD-60-P series portable dumpers exploded parts diagram and bill of materials

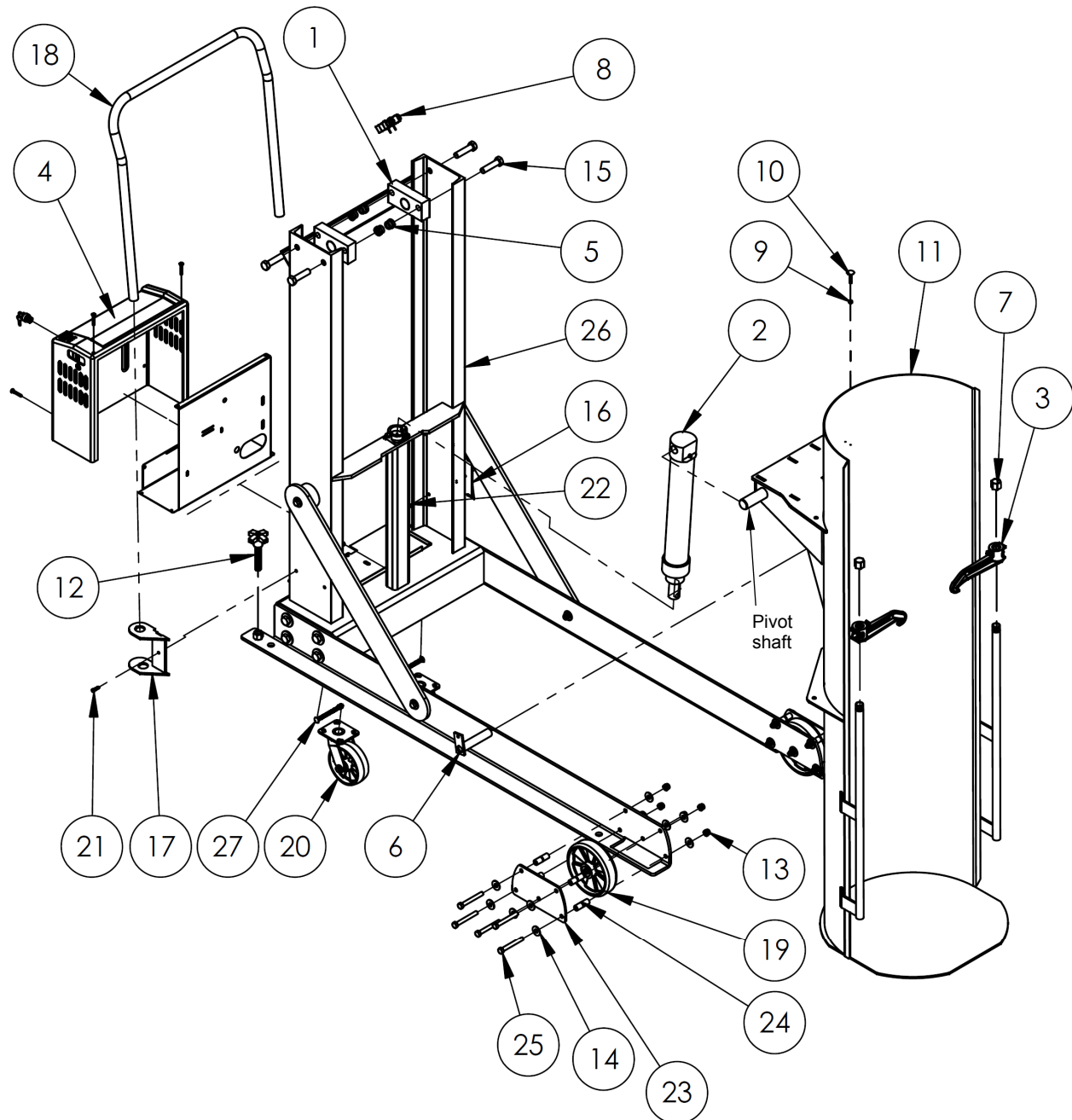

Item no.	Part no.	Description	Qty	Item no.	Part no.	Description	Qty
1	09-512-001	Hinge block assembly	2	15	13365	$\frac{3}{4}$ " - 10 x 3" HHCS #5 plain bolt	4
2	99-021-909	Hydraulic cylinder, 2 $\frac{1}{2}$ " x 18"	1	16	09-525-008	Weldment, handle bracket, left	1
3	09-537-013	Assembly, drum clamp, casting	2	17	09-525-009	Weldment, handle bracket, right	1
4	99-158-008	Modular power unit, no push buttons	1	18	16-025-028	Handle, push handles, chromed	1
5	37039	Nylock nut, zinc-plated, $\frac{3}{4}$ " - 10	4	19	16-132-216	Caster, 8", glass filled nylon	2
6	24-511-030	Pin assembly, cylinder	1	20	16-132-262	6" x 2" glass filled nylon swivel caster	2
7	09-145-020	Threaded pipe cap	2	21	11005	$\frac{1}{4}$ " - 20 x 1" HHCS #2 zinc-plated bolt	2
8	01-022-021	Switch, limit, roller arm	1	22	36104	$\frac{3}{16}$ " - 18 grade A zinc-plated hex nut	2
9	36102	Hex nut, grade A, zinc-plated, $\frac{1}{4}$ " - 20	1	23	09-016-169	Bracket, wheel	2
10	22805	Elevator bolt, limit switch	1	24	16-111-003	Sleeve bearing for 2" wheel	8
11	09-545-031	Weldment, subassembly, chute	1	25	11219	$\frac{1}{2}$ " - 13 x 4" hex head bolt	10
12	08-025-008	4-handle bolt, 4"	2	26	09-514-127	Weldment, frame, stationary	1
13	37030	$\frac{1}{2}$ " - 13 nylon insert lock nut	10	27	99-612-001	$\frac{3}{8}$ " - 16 x 5" bolt and nut combo.	2
14	33012	$\frac{1}{2}$ " flat washer, low carbon, zinc finish	20				

FIG. 8: HDD-72-P series portable dumpers exploded parts diagram and bill of materials

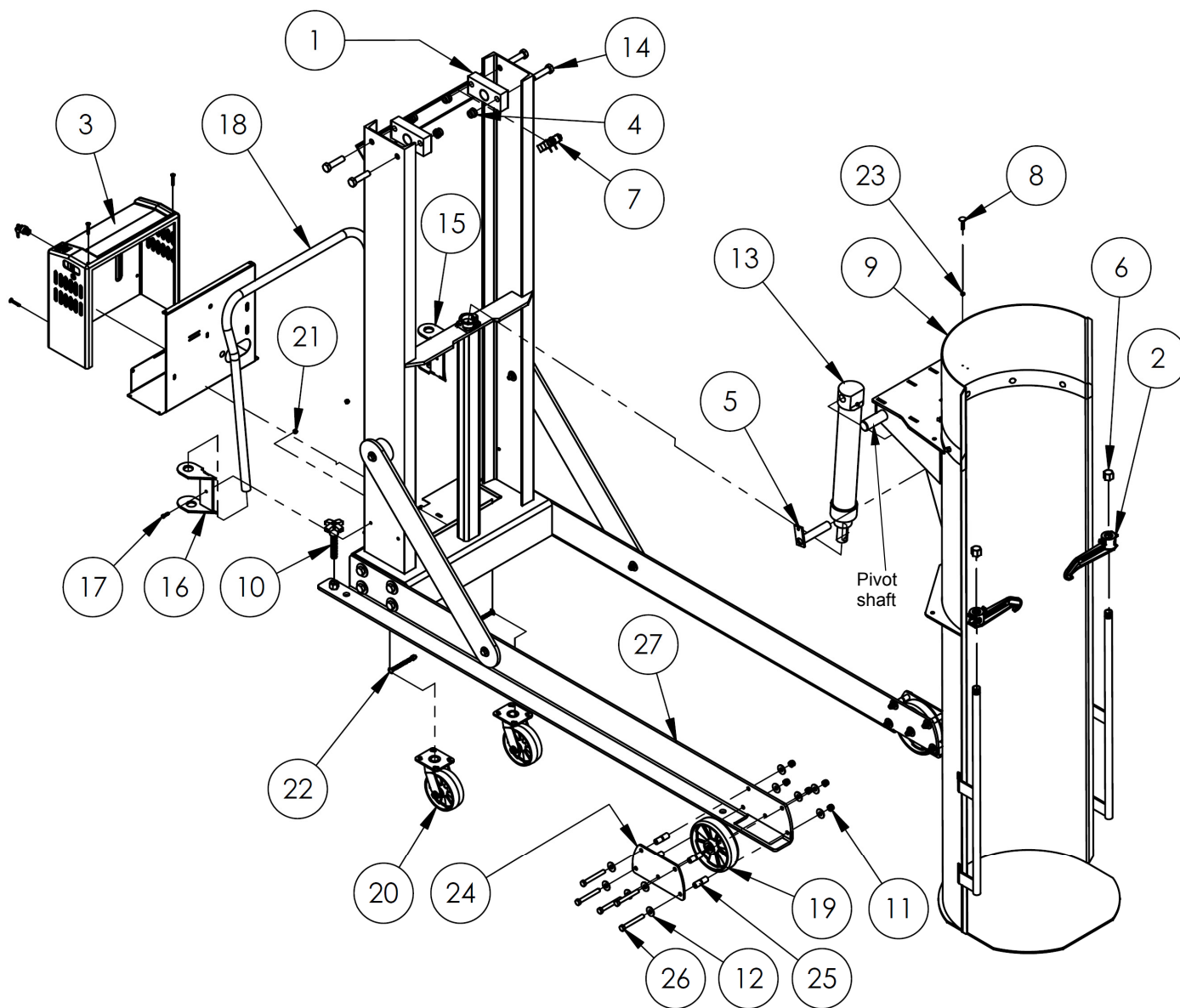

Item no.	Part no.	Description	Qty	Item no.	Part no.	Description	Qty
1	09-512-001	Hinge block assembly	2	15	09-525-008	Weldment, handle bracket, left	1
2	09-537-013	Assembly, drum clamp, casting	2	16	09-525-009	Weldment, handle bracket, right	1
3	99-158-008	Modular power unit, no push buttons	1	17	11005	1/4"-20 x 1" HHCS #2 zinc-plated bolt	2
4	37039	Nylock nut, zinc-plated, 3/4" - 10	4	18	16-025-028	Handle, push handles, chromed	1
5	24-511-030	Pin assembly, cylinder	1	19	16-132-216	Caster, 8", glass filled nylon	2
6	09-145-020	Threaded pipe cap	2	20	16-132-262	6" x 2" glass filled nylon swivel caster	2
7	01-022-021	Switch, limit, roller arm	1	21	36104	5/16"-18 grade A zinc-plated hex nut	2
8	22805	Elevator bolt, limit switch	1	22	99-612-001	3/8"-16 x 5" bolt and nut combo.	2
9	09-545-031	Weldment, subassembly, chute	1	23	36102	Hex nut, grade A, zinc-plated, 1/4" - 20	1
10	08-025-008	4-handle bolt, 4"	2	24	09-016-169	Bracket, wheel	2
11	37030	1/2" - 13 nylon insert lock nut	10	25	16-111-003	Sleeve bearing for 2" wheel	8
12	33012	1/2" flat washer, low carbon, zinc finish	20	26	11219	1/2"-13 x 4" hex head bolt	10
13	99-021-909 09-021-018	Hydraulic cylinder: 2 1/2" x 18" 3" x 18" (HDD-72-15-P)	1	27	09-514-127	Weldment, frame, stationary	1
14	13365	3/4" - 10 x 3" HHCS #5 plain bolt	4				

Installation instructions (stationary units):

- Step 1: Position the dumper where desired with a forklift.
- Step 2: Drill holes approximately 4in. (10cm) deep.
- Step 3: Secure the dumper to the floor by inserting $\frac{3}{4}$ " anchor bolts through the bolt holes in the base frame.
- Step 4: Shim and/or grout the sides of the frame as necessary to achieve levelness.
- Step 5: (AC powered units) Connect the power cord to the power supply.

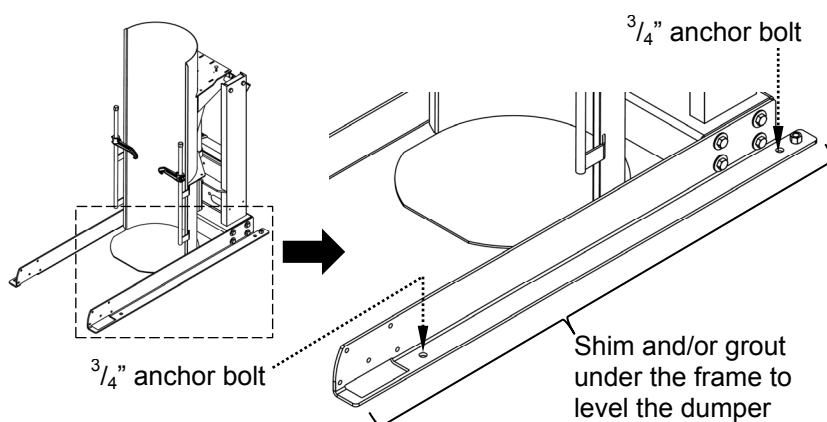

Loading the dumper:

1. Use only properly sized waste containers: HDD-series dumpers are designed to accept 33 gallon and 55 gallon steel, plastic, and fiber drums.
2. Load the drum onto the chute: Place the drum on the base plate of the chute. The drum should rest against the back of the chute.
3. Apply the drum retainers (see diagrams in "Inspections" below): to prevent the drum from sliding out of the chute, move the retainers up or down the rails as necessary and into solid contact with the top of the drum. To move the retainers, press the rail clamps down. The hook at the end of each retainer must contact the inside wall of the drum.
4. Dump the drum: press the white (raise) button on the pendant controller to raise the chute to the dumping position. In response to the input from the controller, the piston extends and raises the bottom end of the chute. The piston extends only while the operator presses the white button. When the button is released, the cylinder stops extending and the chute stops moving. The chute maintains whatever position it is in when the button is released.

NOTE: If the net weight of the drum and its contents exceeds the capacity of the dumper, a relief valve in the hydraulic system will open. While the relief valve is open, the piston cannot extend. Consequently, the chute will not move.

5. Return the chute to the loading position: press the black (lower) button on the controller to retract the piston. As the piston retracts, it pulls the bottom end of the chute towards the ground. If the DOWN button is released before the chute is completely lowered, the chute will maintain its position.

Inspections: (Refer to FIGS. 1-8, p. 5-10)

Before each use, inspect the listed components:

1. Modular power unit, pendant controller, and wiring: examine all wires for frays, cuts, tears, etc. (DC-powered units) Check battery charge status. Cycle the chute all the way up and all the way down. Recharge the battery, if necessary.
2. Hydraulic system: check the reservoir and all hoses for pinches, kinks, punctures, and leaks.
3. Drum retainers and clamp rails: examine the retainers for damage including bends, cracks, and looseness. Each clamp should maintain position along the rail (i.e. should not slide).
4. Frame: check the hinge blocks, pivot shafts, cylinder brackets (at each end of cylinder at attachment points to the frame and the chute), legs, vertical frame, and chute for cracks, damaged welds, severe wear, and corrosion.
5. Cylinder and limit switches: verify normal function. Cycle the chute through a complete dumping sequence (fully rotated and back to the ground). When the chute reaches dumping height, the power unit should stop running. The piston should extend and retract smoothly without binding or jerking. Listen for unusual sounds that might indicate binding or grinding during operation and watch for unusual movement. If you observe any unusual sound or movement, do not use the

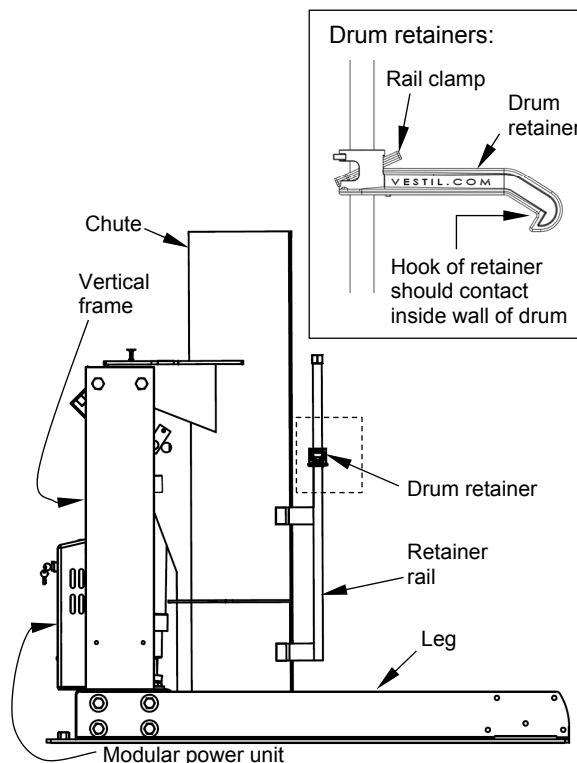

dumper until it has been restored to normal operating condition.

At least once per month, inspect the dumper as follows:

1. Oil level: remove the cover from the modular power unit. Then, fully raise the chute (to the 45° “dumping position”) and observe the level of oil in the reservoir. The surface of the oil should be 1 to 1½ inches below the fill hole. If oil is needed, add oil as specified below in “Oil specifications”.
2. Pivot points: check the dumper for excessive wear. Pay particular attention to pivot points between hydraulic cylinders and cylinder brackets, and between pivot shafts and hinge blocks.
3. Floor connection points: anchor bolts should prevent the frame from lifting off of the ground during chute operation. Concrete around each anchor bolt should be intact, i.e. not cracked or chipped.
4. Fasteners: check each fastener connection (nuts, bolts, pins, etc.). Tighten loose connections. Replace all damaged hardware.
5. Hydraulic hoses and electrical wires: check each wire and hose for damage (frays, kinks etc.).
6. Labels: labels should be easily readable, undamaged, and be affixed to the dumper as shown in the “Labeling diagram” on p. 23.

Oil specifications: *At least once per year* change the hydraulic oil. Change the oil as soon as it becomes gritty or looks milky (indicating that water is present). With the chute in the fully lowered position, drain the oil and replace it with either Dexron transmission fluid or anti-wear hydraulic oil viscosity grade 150 SUS at 100°F (ISO 32 cSt at 40°C).

Power unit operation

The drum dumper is powered by an electric motor directly coupled to a gear pump. The pump pressurizes the hydraulic fluid. Fluid pressure causes the piston of the hydraulic cylinder to extend. Piston extension causes the bottom of the chute to rotate until it is elevated above the top of the chute. A hydraulic manifold bolted directly onto the gear pump houses the hydraulic control components. Each component is rated for 3,000psi working pressure.

Important components of the power unit include:

- Electric motor: the motor is either AC powered (wall socket) or DC powered (battery). AC-powered motors can be wired for either single-phase or three-phase operation. Regardless of phase configuration, every motor is dual-voltage capable.
- Gear pump: the pump shaft is directly coupled to the shaft of the electric motor. Several displacements are available to match the horsepower of the motor selected.
- Check valve: prevents backflow of fluid through the pump and to the reservoir. Because fluid can only flow in response to an electrical signal from the pendant controller, the chute can maintain any position between the raised and lowered configurations.
- Pressure relief valve: opens a path for fluid to flow back to the reservoir if fluid pressure exceeds 3,000psi.
- Lowering solenoid valve: electrically-operated cartridge valve with an integral screen to keep contaminants from entering the valve.
- Pressure compensated flow control spool: this feature regulates the flow of hydraulic oil from the cylinder back to the reservoir. It is located beneath the lowering valve. This component allows the table to lower at a predetermined constant rate regardless of the weight of the dumper and contents. Several sizes are available.
- Displacement style hydraulic cylinder: each cylinder includes a bleeder valve located at top end for removing air from the hydraulic system.
- Velocity fuse: a safety device installed in the hose port of each cylinder. If a hose is punctured while the unit is operating, the velocity fuse closes automatically. The chute remains stationary until pressure is reapplied to the system.
- Hydraulic fluid: HO150 hydraulic fluid. To replenish the fluid, add anti-wear hydraulic fluid with a viscosity grade of 150 SUS at 100°F (ISO 32 @ 40°C) like AW-32 or Dexron transmission fluid.

Sequence of operation:

To raise/tilt the chute, press the white (UP) button. In response, the motor turns and rotates the gear pump. As the pump rotates, oil is drawn from the reservoir, passes through the suction filter, and enters the pump.

- The gear pump propels oil through the check valve to the lift cylinder.
- Releasing the white button during operation immediately halts chute movement. Additionally, an electrical upper travel limit switch automatically turns off the motor when the chute reaches a 45° angle to the ground (horizontal).

To lower the chute, press the black (DOWN) button.

- Lowering valve opens which bypasses the check valve and allows oil in the cylinder to flow to the reservoir (through return hoses). Oil flow to the reservoir is regulated by the pressure compensated flow control valve. By regulating the volume of oil that can flow through the spool, the speed at which the chute lowers is kept constant.
- Releasing the DOWN button during operation causes all chute movement to stop. The chute will remain in the same position until you press either button on the pendant controller.

Cleaning lowering solenoid valve: If the chute slowly loses elevation without pressing the DOWN button, lower the chute completely. Then, remove, inspect, and clean the lowering cartridge valve in the following manner:

1. Lower the chute completely and turn off electrical power to the unit. If your dumper is AC powered, unplug the electrical cord from the wall socket. If your unit is DC (battery) powered, turn the power switch to the OFF position.
2. Unload the dumper.
3. Remove the nut that fastens the solenoid coil to the valve stem; then remove the coil and unscrew the valve from the manifold.
4. Inspect the valve for blockage.
5. Inspect O-rings and back-up washers for cuts, tears, etc.
6. Submerge the valve in mineral spirits or kerosene.
7. Use a thin tool, such as a small screwdriver or a hex wrench, to push the poppet in and out several times from the bottom end of the valve. The valve should move freely, about 1/16" between the closed and open positions. If the poppet sticks, the valve stem might be bent. Replace the poppet if it doesn't free up after cleaning.
8. Remove mineral oil from the valve with compressed air.
9. Move the poppet in and out.
10. Inspect the bottom of the valve cavity in the manifold for foreign matter.
11. With the thin tool, press the middle of the flow control spool, which is located in the bottom of the cavity. It should move down and up smoothly.
12. Reinstall the valve in the manifold and tighten it to 20 lb-ft of torque.

Bleeding air from hydraulic system: If the chute lowers extremely slowly or does not lower, air in the cylinders might be the culprit. Air in the hydraulic system causes the velocity fuse to close, which traps oil in the cylinder. To overcome this problem, air must be "bled" from the system.

- Completely lower the chute and unload it;
- Locate the bleeder valve located at the top of the cylinder (it looks like a grease zerk). Hold a rag over the valve and open it about a half turn with a 1/4" or 5/16" wrench. Oil and air will sputter from the valve. Jog the motor by pressing the white (UP) button for just a second. If air continues to escape from the bleeder valve, jog the motor several more times. Wait at least 5 seconds between successive jogs.
- Close the valve once air no longer is heard or seen bubbling out of the valve. At this point, just a clear stream of oil is seen flowing from the bleeder valve. Close the valve.
- Remove the cover from the modular power unit and check the oil level in the reservoir. If the surface of the oil is lower than 1 to 1½ in. below the fill hole, then add oil until it is between 1 and 1½ inches of the fill hole. Add only anti-wear hydraulic fluid with a viscosity grade of 150 SUS at 100°F (ISO 32 @ 40°C) like AW-32 or Dexron transmission fluid.

FIG. 9: Hydraulic circuit diagram

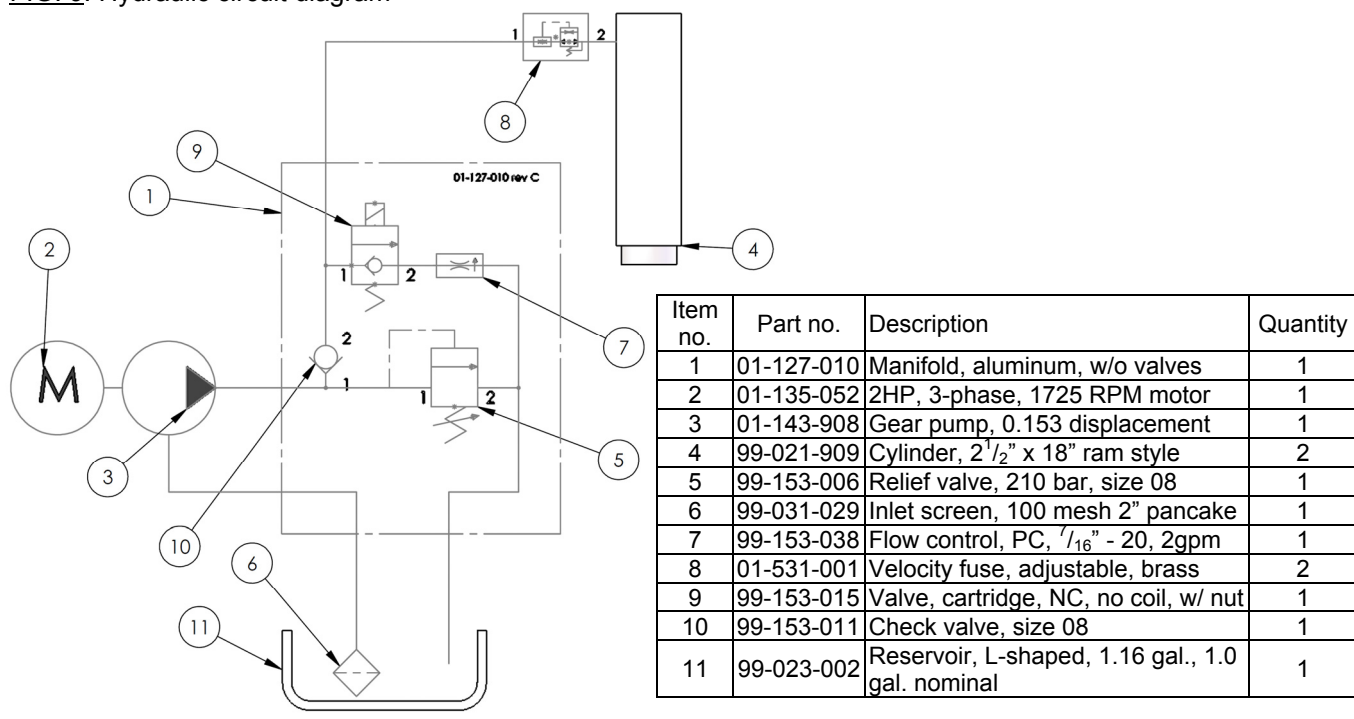
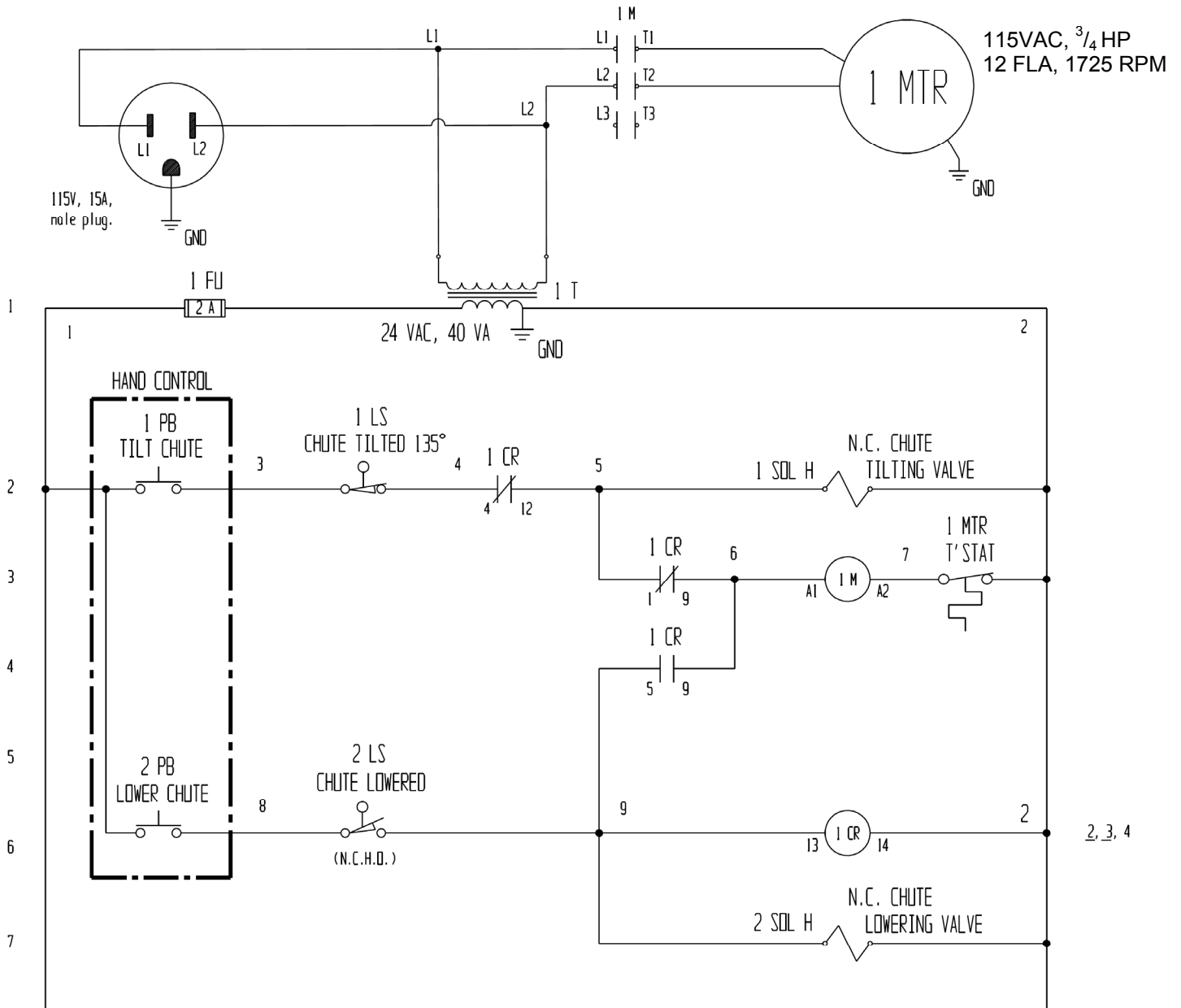

FIG. 10A: 115VAC, Electrical Circuit Diagram (09124017 Rev. D)

NOTE: In this diagram, all components are represented with the chute in "home" location, i.e. resting, lowered position.



NOTE: Overcurrent and short-circuit protection should be provided by the end user in accordance with recommendations and requirements in NEC (NFPA 70) and local codes.

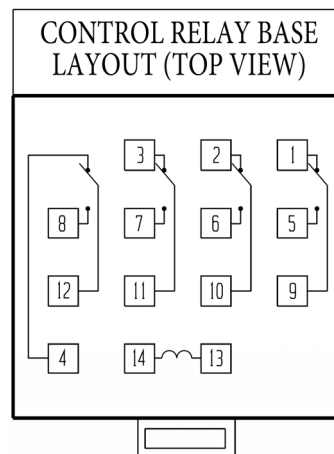
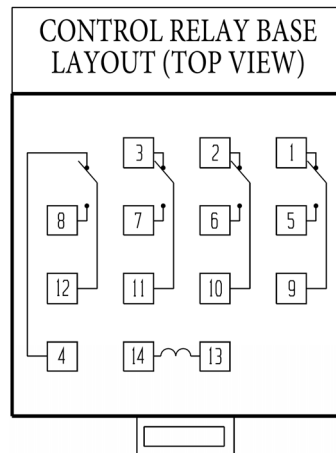
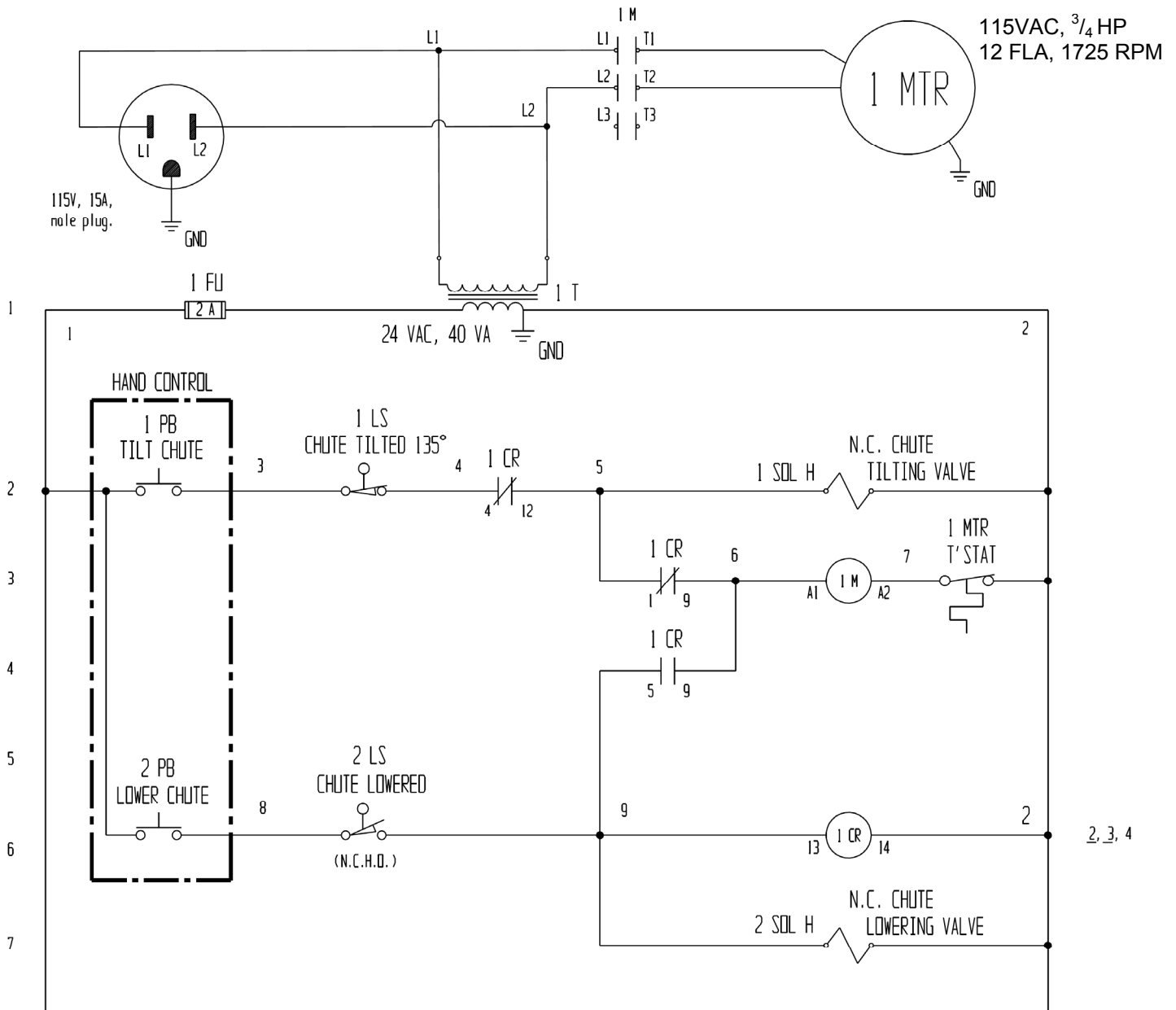

FIG. 10B: 115VAC, Upper & Lower Limit Switches, Electrical Circuit Diagram (09124014 Rev. C)

NOTE: In this diagram, all components are represented with the chute in “home” location, i.e. resting, lowered position.



NOTE: Overcurrent and short-circuit protection should be provided by the end user in accordance with recommendations and requirements in NEC (NFPA 70) and local codes.

FIG. 10C: 208-230VAC, 1-phase, electrical circuit diagram (09124018 Rev. C)

NOTE: In this diagram, all components are represented with the chute in “home” location, i.e. resting, lowered position.

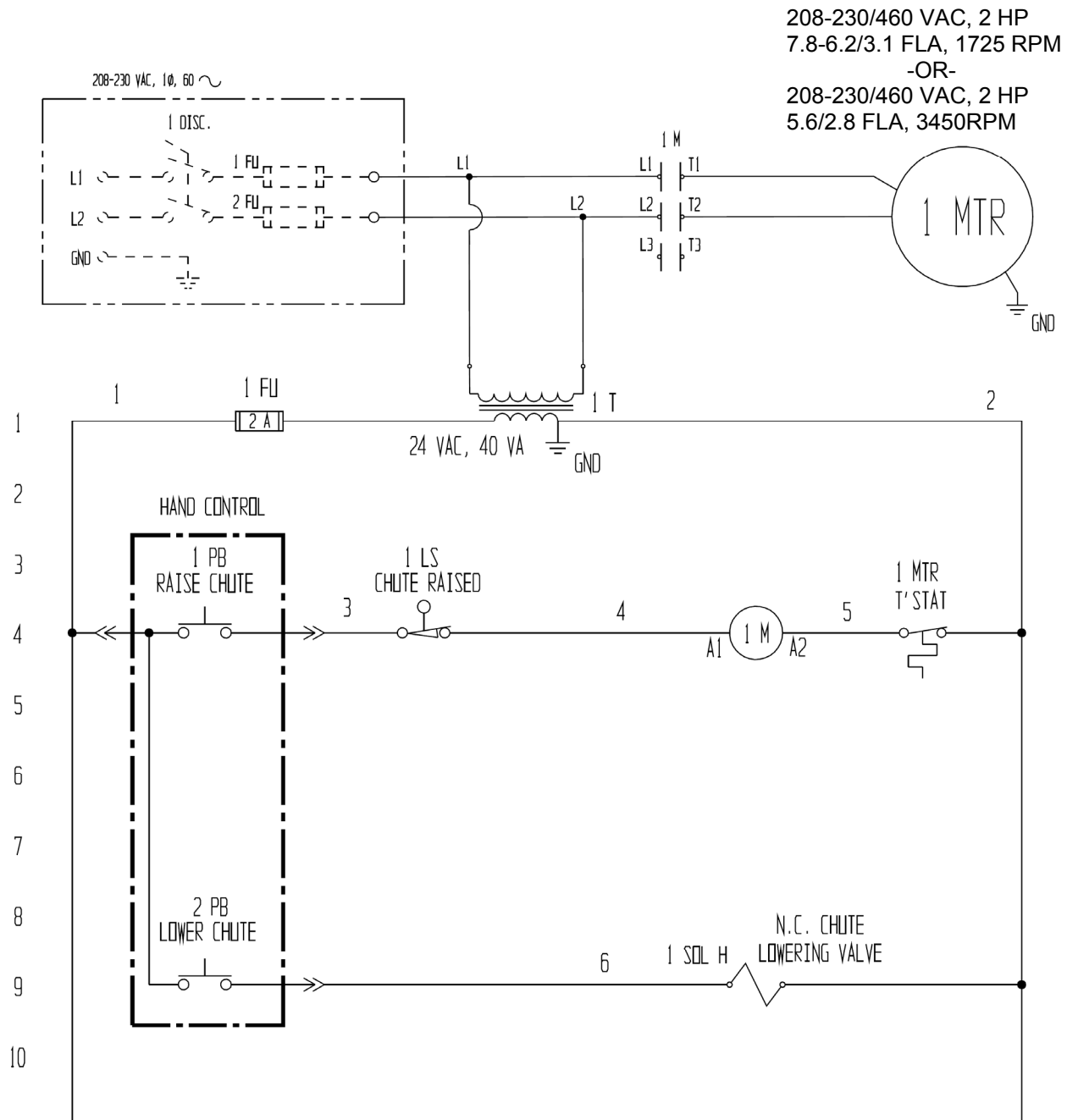

NOTE: Overcurrent and short-circuit protection should be provided by the end user in accordance with recommendations and requirements in NEC (NFPA 70) and local codes.

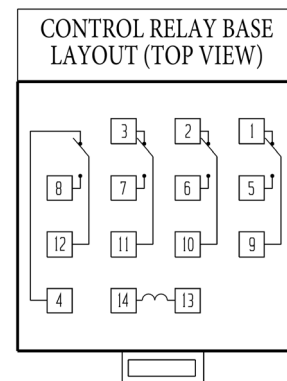
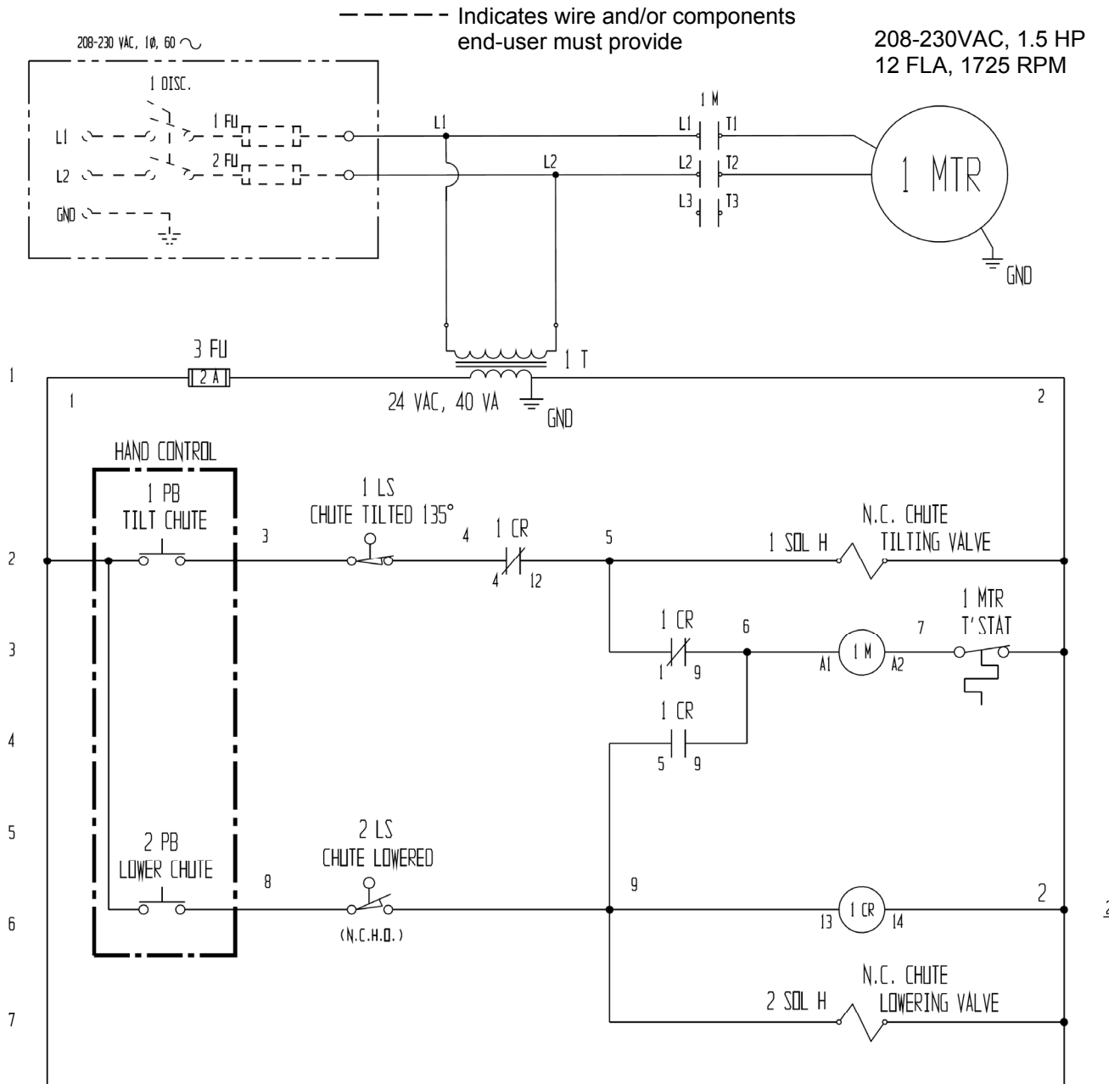

FIG. 10D: 208-230VAC, Upper & Lower Limit Switches, 1-phase electrical circuit diagram (09124015 Rev. C)

NOTE: In this diagram, all components are represented with the chute in “home” location, i.e. resting, lowered position.



NOTE: Overcurrent and short-circuit protection should be provided by the end user in accordance with recommendations and requirements in NEC (NFPA 70) and local codes.

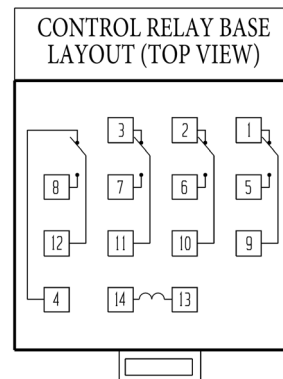
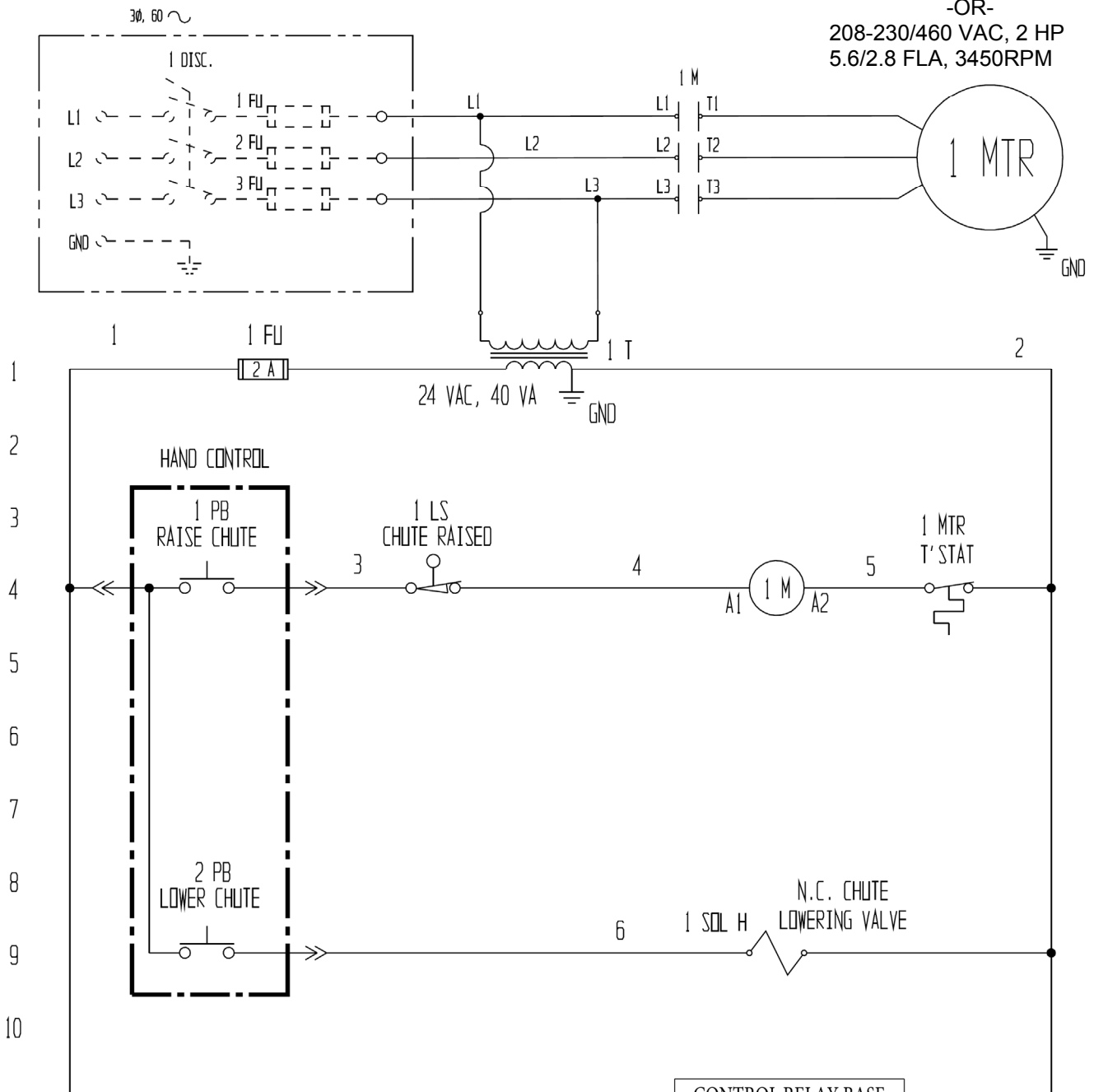

FIG. 10E: 3-phase 208-230/460 VAC, electrical circuit diagram (09124019 Rev. C)

NOTE: In this diagram, all components are represented with the chute in “home” location, i.e. resting, lowered position.

----- Indicates wire and/or components end-user must provide

208-230/460 VAC, 2 HP
7.8-6.2/3.1 FLA, 1725 RPM
-OR-
208-230/460 VAC, 2 HP
5.6/2.8 FLA, 3450RPM



NOTE: Overcurrent and short-circuit protection should be provided by the end user in accordance with recommendations and requirements in NEC (NFPA 70) and local codes.

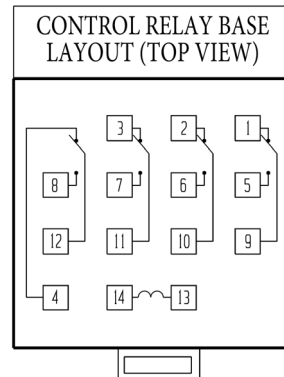
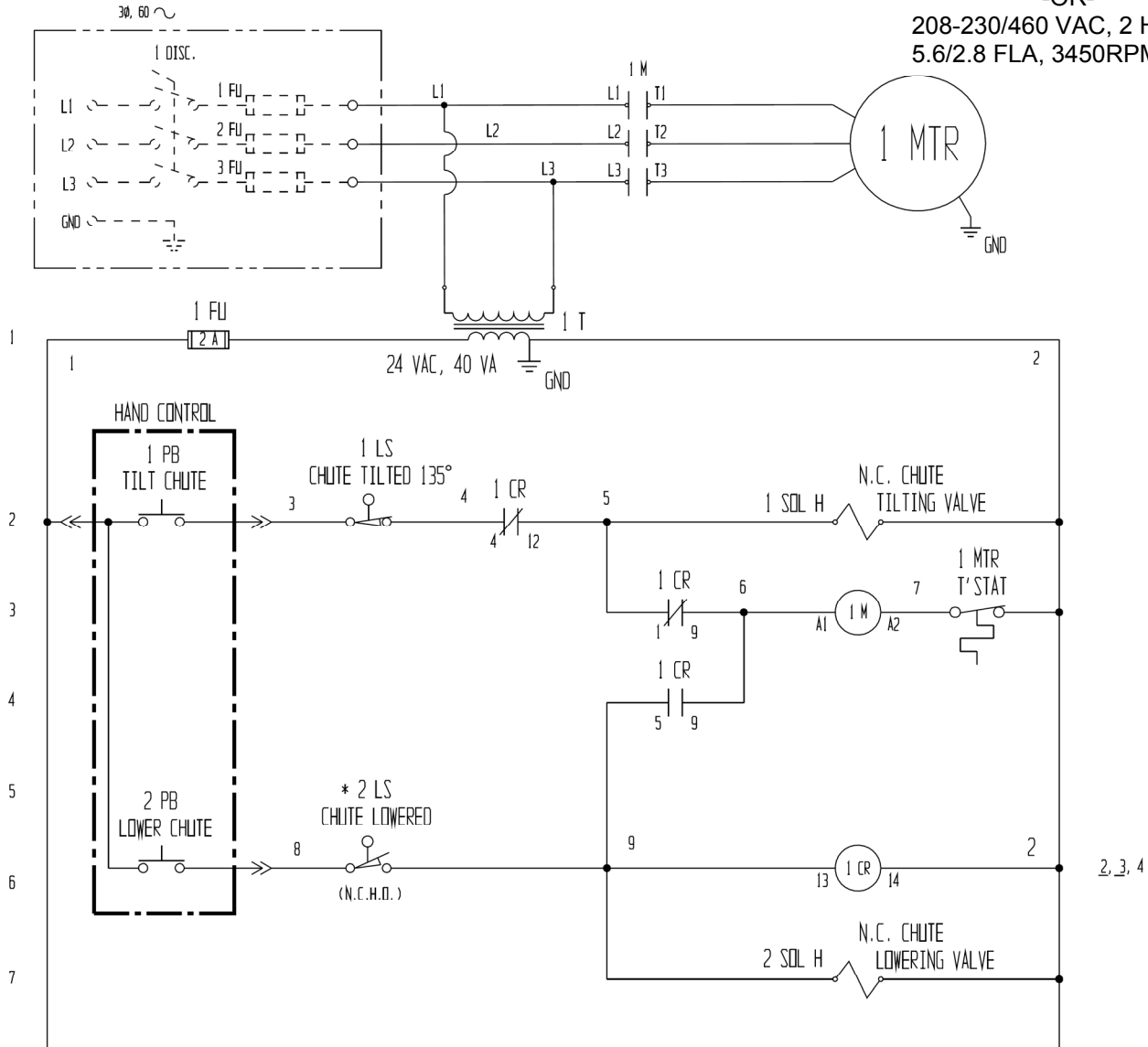

FIG. 10F: 3-phase 208-230/460 VAC, Upper & Lower Limit Switches, electrical circuit diagram (09124016 Rev. C)

NOTE: In this diagram, all components are represented with the chute in "home" location, i.e. resting, lowered position.

----- Indicates wire and/or components end-user must provide

208-230/460 VAC, 2 HP
7.8-6.2/3.1 FLA, 1725 RPM
-OR-
208-230/460 VAC, 2 HP
5.6/2.8 FLA, 3450RPM



NOTE: Overcurrent and short-circuit protection should be provided by the end user in accordance with recommendations and requirements in NEC (NFPA 70) and local codes.

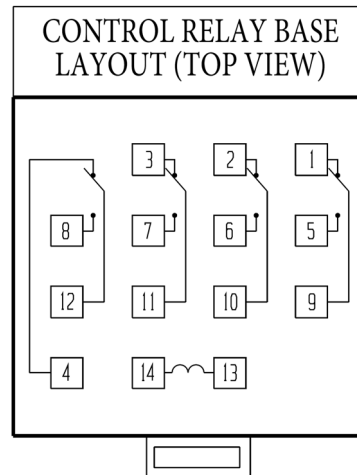
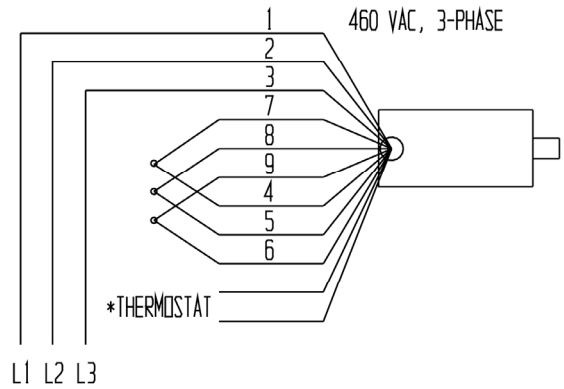
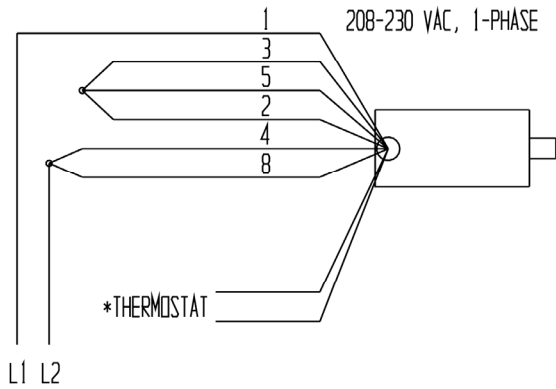
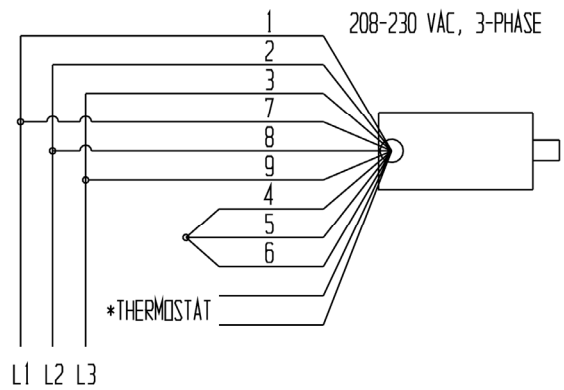
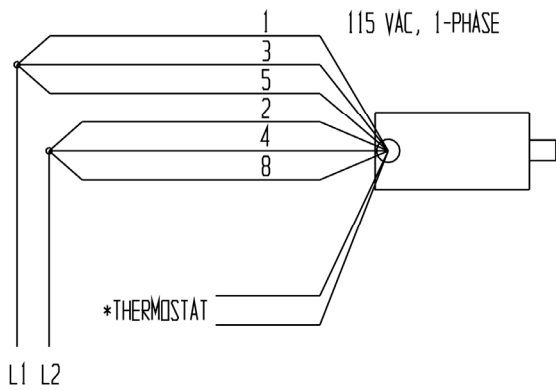

FIG. 11: Motor lead connection diagrams for all 0.5HP, 0.75HP, & 3hp single-phase motors and for all 2HP, 5.5HP, and 6.5HP three phase motors



Attach thermostat leads to:
 1) Grounded side of the transformer secondary; and
 2) Motor relay coil.
 It does not matter which lead attaches to each location.

Transformer wiring diagram:

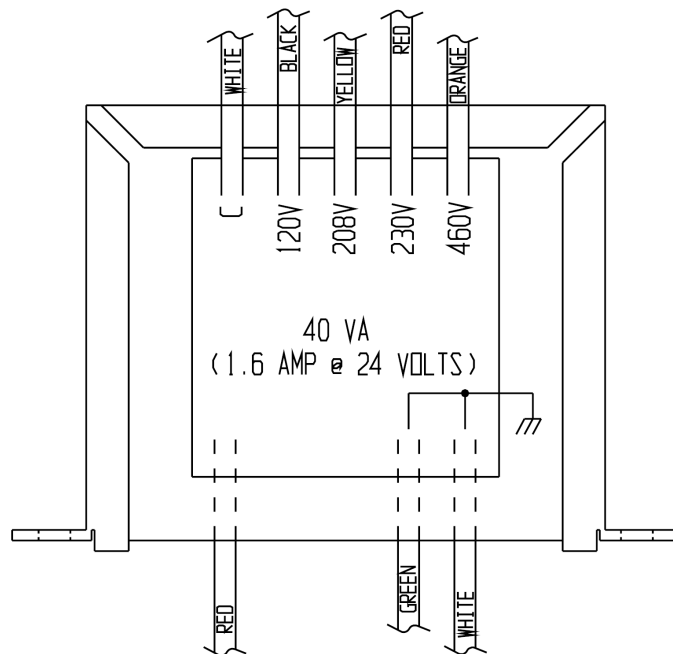
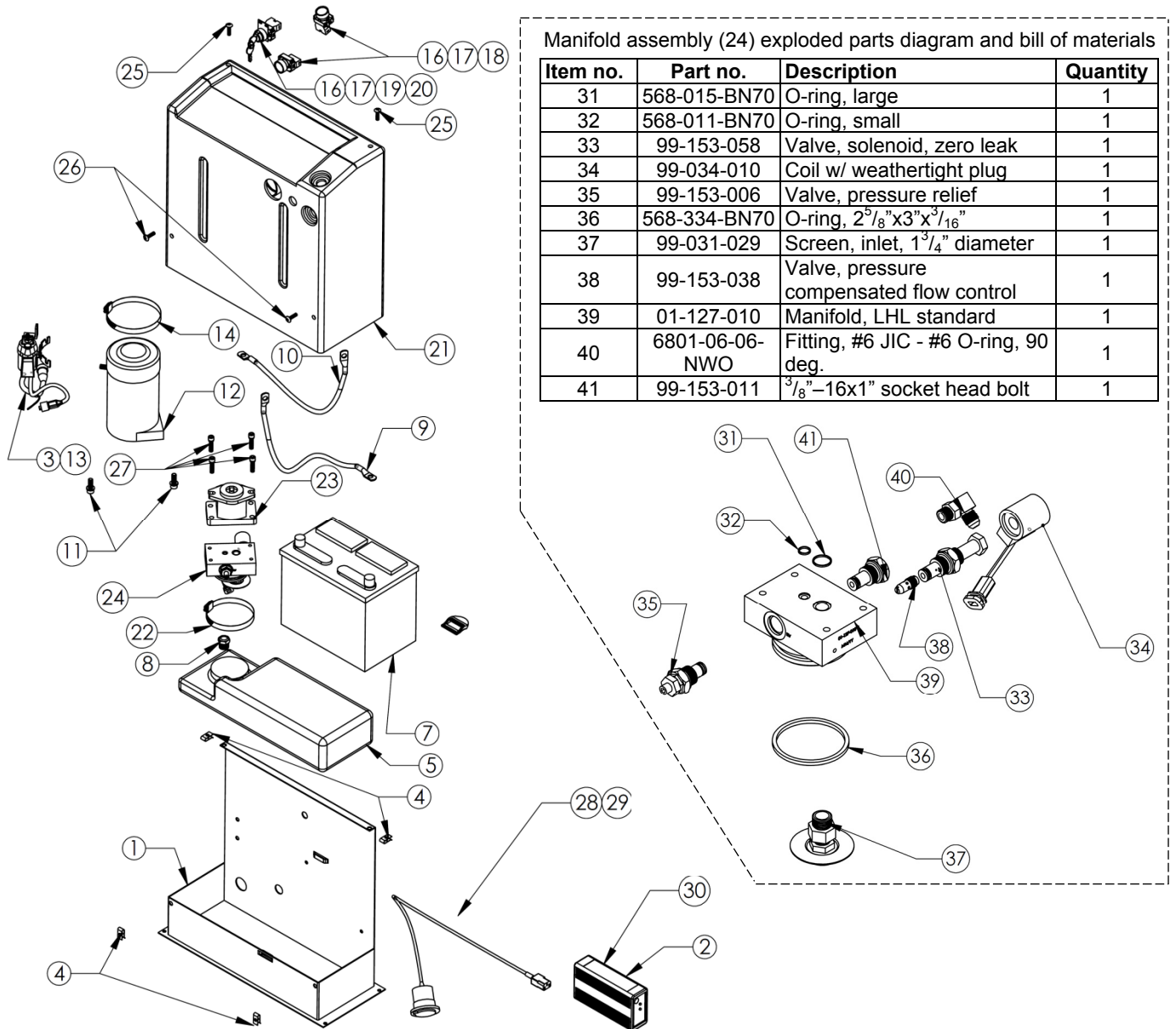
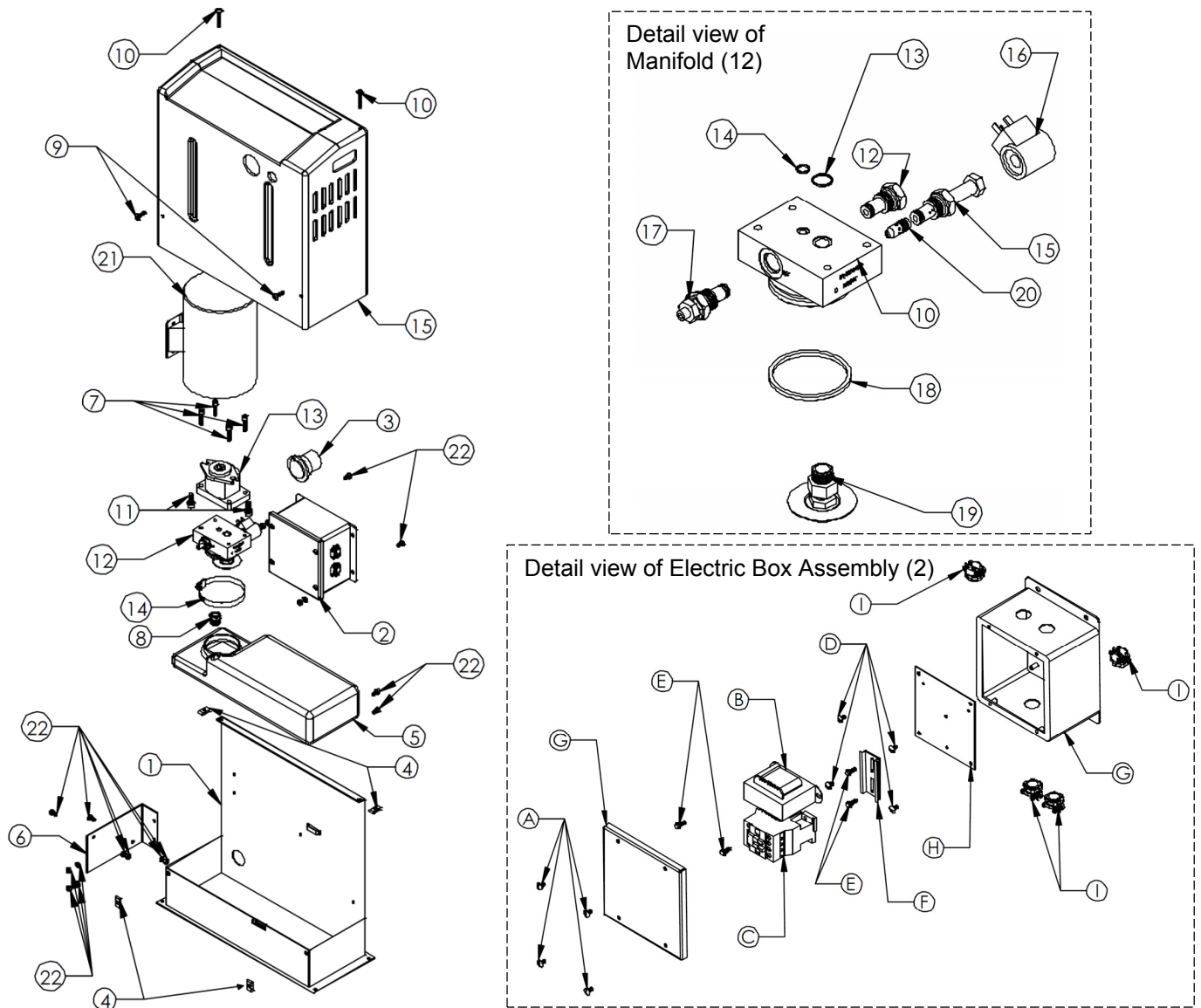

FIG. 12A: DC modular power unit exploded parts diagram and bill of materials



Item no.	Part no.	Description	Quantity	Item no.	Part no.	Description	Quantity
1	99-016-933	Base	1	16	Zb2bz009	Contact block base	2
2	21-034-008	Battery charger	1	17	Zb2be101	Contact block, N.O.	2
3	99-533-008	Adaptor, hand control	1	18	Zb2ba2c	Operator, black, flush, non-illuminated	2
4	37927	Tinnerman clip	4	21	99-024-010	Cover, plastic	1
5	99-023-001	Reservoir	1	22	HS52	Clamp, worm gear hose	1
6	99-034-013	Battery strap	1	23	01-143-906	Pump, hydraulic gear	1
7	99-139-003	Battery	1	*24	01-627-010	Manifold assembly (see p. 16)	1
8	01-116-003	Breather, vent, brass fitting	1	25	29201	Screw, machine, 1/4"-20x1 1/4"	2
9	15-533-013	23" black #4 AWG battery cable	1	26	29185	Screw, machine, 1/4"-20x1"	2
10	15-533-014	23" black #4 AWG battery cable	1	27	23255	Bolt, socket head, 5/16"-18x1"	4
11	23305	3/8"-16x1" socket head bolt	2	28	33687	Washer, lock, 5/16"	4
	33688	3/8" lock washer	2		152400-03	Molded cord, charger connect	1
	33008	3/8" flat washer	2				
12	99-135-011	Motor	1	29	21-034-025	Flanged inlet w/ locking ring	1
13	15-022-004	Relay, start solenoid	1	30	3MTST3540	1" hook & loop strip	10"
14	HS64	Clamp, worm gear hose	1				
15	BG-12V	Gauge, battery, charge indicator	1				

FIG. 12B: AC modular power unit exploded parts diagram and bill of materials



Item no.	Part no.	Description	Qty	Item no.	Part no.	Description	Qty
1	99-016-933	MPU base bracket	1	11	23305	$\frac{3}{8}$ " - 16 x 1" socket head bolt	2
2		Electric box assembly	1		33688	$\frac{3}{8}$ " lock washer	2
3	21-034-005	Connector, flanged inlet plug	1		33008	$\frac{3}{8}$ " flat washer	2
4	37927	U nut	4	12	01-627-010	LHL manifold assembly	1
5	99-023-001	Reservoir	1	13	01-143-906	Hydraulic gear pump	1
6		Motor brace	1	14	99-145-061	Worm gear hose clamp	1
7	23255	$\frac{5}{16}$ " - 18 x 1" socket head bolt	4	15	99-024-029	Plastic cover (gray)	1
	33687	$\frac{5}{16}$ " lock washer	4	16	ZB2BZ009	Contact block base	2
8	01-116-003	Breather, vent, brass fitting	1	17	ZB2BE101	Contact block, n.o.	2
9	29185	$\frac{1}{4}$ " - 20 x 1" Phillips head truss machine screw	2	18	ZB2BA2C	Operator, black, flush, non-illuminated	2
		$\frac{1}{4}$ " - 20 x 1 $\frac{3}{4}$ " machine screw	2	21	99-135-003	Motor, $\frac{3}{4}$ HP	1
10	29201				11005	$\frac{1}{4}$ " - 20 - 1" hex head bolt	6
					33004	$\frac{1}{4}$ " flat washer	6
					33618	$\frac{1}{4}$ " lock washer	6
					36102	$\frac{1}{4}$ " - 20 hex nut	6
A	71616	10-32 x $\frac{5}{8}$ " truss head machine screw	4	F	Tb-track	39" rail, din, aluminum	3"
B	01-129-001	Control transformer	1	G	01-029-006	Junction box with screw lid	1
C	132560	Contactor, motor, UL Listed	1	H	Ab66jp	Plate, enclosure	1
D	27531	10-32 x $\frac{1}{4}$ " z-plated machine screw	4	I	C500	Connector, clamp, NM, Romex	4
E	32028	#8 - 18 x $\frac{1}{2}$ " self-tapping screw	4				

Troubleshooting Guide

⚠WARNING DO NOT attempt to resolve any issue discussed below UNTIL the chute is fully lowered and the power supply is disconnected.

<u>Issue:</u>	<u>Possible cause(s):</u>	<u>Solution:</u>
1. Power unit doesn't run when white (UP) button is pressed.	1a. Transformer fuse is blown. b. No supply voltage. c. Upper-travel limit switch is engaged or bad. d. Faulty connection in control circuit. e. Bad control transformer. f. Open motor relay coil. g. (DC units) Low battery voltage.	1a. Test with meter; replace if bad. b. Test with meter. Check fuses, breakers, and overloads to determine the cause. c. Inspect and test switch. Replace if bad. d. Test all parts of circuit with meter. e. Check for 24 VAC; replace if bad. f. Test with meter; replace if bad. g. Test with meter. Charge battery if low (is motor relay LED on?)
2. Motor runs properly, but chute doesn't move. Motor and pump are quiet.	2a. Incorrect motor rotation. b. Pump failure. c. Low hydraulic fluid level.	2a. Verify motor shaft rotates counterclockwise. b. Consult factory for replacement. c. Ensure reservoir is filled.
3. Motor hums, chatters, or buzzes, or some type of squeal can be heard, but the chute does not move or only moves very slowly.	3a. See 2b above. b. Excess voltage drop to motor due to power wire size too small, wire run too long, or incoming voltage too low. c. (3-phase motors) Motor is "single-phasing". d. Pressure relief opening at full pressure. e. Contamination holding open the lowering valve or the check valve.	3a. Same as 2b. b. Check power installation for adequacy. Check incoming voltage <i>while motor is running</i> . Correct problem(s). c. Determine cause of loss of voltage on one phase; correct. d. Check for structural damage or binding of the rollers, etc. Check for chute overload condition. e. Remove and inspect. Clean the valve with mineral spirits.
4. Chute elevates, then drifts down.	4. See 3e above.	4. Same as 3e.
5. Chute lowers too slowly.	5a. Flow control spool is stuck. b. Pinched hose. c. Velocity fuse locking (chute only slowly creeps down).	5a. Remove plug from FC port; push down on the center of the flow spool to ensure it moves freely. b. Check pressure, supply, and return hoses for kinks. c. Same as 7 (below).
6. Chute lowers too quickly.	6a. See 3e. b. Flow control spool is stuck.	6a. Same as 3e. b. Same as 5a.
7. Spongy or jerky chute motion.	7. Air in the hydraulic cylinders.	7. Bleed air per procedure described on p. 10 of this manual.

Labeling diagram:

The drum dumper should always be labeled as shown in the diagram below. Replace labels that are missing, damaged, faded, or not easily readable.

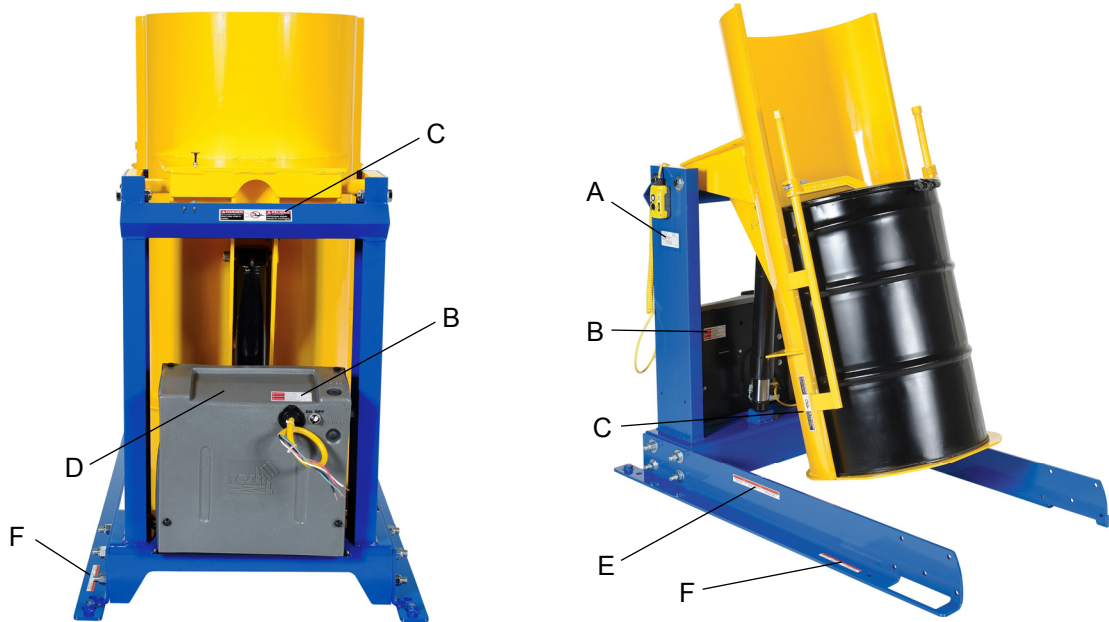

A: Label 287 (model, capacity, serial no.)

DATE / FECHA/DATE:	
MODEL/ MODÉLO/ MODELÉ:	
SERIAL/ SERIE/ SÉRIE:	
CAPACITY/ CAPACIDAD/ CAPACITÉ:	
SUPPLY VOLTAGE/ SUMINISTRO DE VOLTAJE/ TENSION D'ALIMENTATION:	AC
FREQUENCY/ FRECUENCIA/ FRÉQUENCE:	HZ
PHASE/ FASE/ PHASE:	
FULL LOAD AMPS/ AMPS DE CARGA COMPLETA/ COURANT À PLEINE CHARGE:	A
ELECTRICAL DIAGRAM/ DIAGRAMA ELECTRICO/ SCHÉMA ÉLECTRIQUE:	

B: Label 221 (risk of electric shock)

	DANGER	ELECTRICAL SHOCK Shut power off and consult owners manual before working on this equipment.	221 Rev 0111
	PELIGRO	EI GOLPE ELECTRICO Corte la corriente consulte el manual de propietario antes de trabajar en este equipo.	
	DANGER	CHOC ELECTRIQUE Couper le courant et consulter le manuel d'utilisation avant de travailler sur cet équipement	

C: Label 824 (on both sides of chute; "Keep clear when in use")

	DANGER		
	To avoid bodily injury, stand clear while in motion.		

NOTICE	NOTA	AVIS
POWER SUPPLY: 115 V/1 Phase/60 HZ		
CONTROL VOLTAGE: 24 V AC		
CORRIENTE: 115 Volt/1 Fase/60 HZ		
VOLTAJE DE CONTROL: 24V CA		
ALIMENTATION ÉLECTRIQUE: 115 V/1 Monophase/ 60 HZ		
VOLTAGE DE CONTRÔLE: 24V AC		

E: Label 208 (on both sides of frame; "Keep clear of pinch point")

WARNING	ADVERTENCIA	AVERTISSEMENT
KEEP CLEAR OF PINCH POINT	MANTÉNGASE ALEJADO DEL PUNTO DE CORTE	SE TENIR À DISTANCE DU POINT DE PINCEMENT

Label 249

NOTICE	NOTA	AVIS
POWER SUPPLY: 208-230V/3 Phase/60 HZ		
CONTROL VOLTAGE: 24V AC		
CORRIENTE: 208-230V/3 Fase/60 HZ		
VOLTAJE DE CONTROL: 24V CA		
ALIMENTATION ÉLECTRIQUE: 208-230V/3 Monophase/ 60 HZ		
VOLTAGE DE CONTRÔLE: 24V AC		

F: Label 204 (on both sides; "Secure frame to floor")

WARNING	ADVERTENCIA	AVERTISSEMENT
SECURE FRAME TO FLOOR	ASEGURE EL BASTIDOR AL PISO	FIXER SOLIDEMENT LE CADRE AU PLANCHER

G: Label 206 (on reservoir inside; hydraulic fluid specifications)

ISO 32 / 150 SUS
HYDRAULIC OIL OR NON-SYNTHETIC TRANSMISSION FLUID
ACEITE HIDRAULICO O LIQUIDOS DE TRANSMISION NO SINTETICOS
HUILE OU LIQUIDE HYDRAULIQUE NON-SYNTHÉTIQUE
VESTIL MANUFACTURING CORPORATION • Phone (260) 665-7586 • www.vestil.com

LIMITED WARRANTY

Vestil Manufacturing Corporation (“Vestil”) warrants this product to be free of defects in material and workmanship during the warranty period. Our warranty obligation is to provide a replacement for a defective original part if the part is covered by the warranty, after we receive a proper request from the warrantee (you) for warranty service.

Who may request service?

Only a warrantee may request service. *You are a warrantee if* you purchased the product from Vestil or from an authorized distributor AND Vestil has been fully paid.

What is an “original part”?

An original part is a part used to make the product as shipped to the warrantee.

What is a “proper request”?

A request for warranty service is proper if Vestil receives: 1) a photocopy of the Customer Invoice that displays the shipping date; AND 2) a written request for warranty service including your name and phone number. Send requests by any of the following methods:

Mail
Vestil Manufacturing Corporation
2999 North Wayne Street, PO Box 507
Angola, IN 46703

Fax
(260) 665-1339
Phone
(260) 665-7586

Email
sales@vestil.com

In the written request, list the parts believed to be defective and include the address where replacements should be delivered.

What is covered under the warranty?

After Vestil receives your request for warranty service, an authorized representative will contact you to determine whether your claim is covered by the warranty. Before providing warranty service, Vestil may require you to send the entire product, or just the defective part or parts, to its facility in Angola, IN. The warranty covers defects in the following *original* dynamic components: motors, hydraulic pumps, electronic controllers, switches and cylinders. It also covers defects in *original* parts that wear under normal usage conditions (“wearing parts”), such as bearings, hoses, wheels, seals, brushes, and batteries.

How long is the warranty period?

The warranty period for original dynamic components is 1 year. For wearing parts, the warranty period is 90 days. The warranty periods begin on the date when Vestil ships the product to the warrantee. If the product was purchased from an authorized distributor, the periods begin when the distributor ships the product. Vestil may, at its sole discretion, extend the warranty periods for products shipped from authorized distributors by *up to* 30 days to account for shipping time.

If a defective part is covered by the warranty, what will Vestil do to correct the problem?

Vestil will provide an appropriate replacement for any *covered* part. An authorized representative of Vestil will contact you to discuss your claim.

What is not covered by the warranty?

1. Labor;
2. Freight;
3. Occurrence of any of the following, which automatically voids the warranty:
 - Product misuse;
 - Negligent operation or repair;
 - Corrosion or use in corrosive environments;
 - Inadequate or improper maintenance;
 - Damage sustained during shipping;
 - Collisions or other incidental contacts causing damage to the product;
 - Unauthorized modifications: DO NOT modify the product IN ANY WAY without first receiving written authorization from Vestil. Modification(s) might make the product unsafe to use or might cause excessive and/or abnormal wear.

Do any other warranties apply to the product?

Vestil Manufacturing Corp. makes no other express warranties. All implied warranties are disclaimed to the extent allowed by law. Any implied warranty not disclaimed is limited in scope to the terms of this Limited Warranty.

